

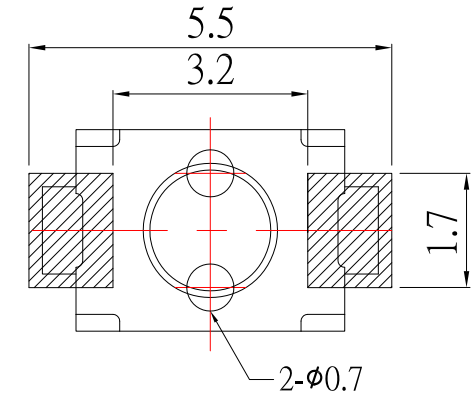

P.C.B. LAYOUT MOUNTING PATTERN

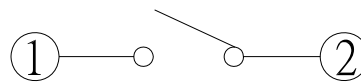

CIRCUIT DIAGRAM



Model No.	H (mm)	Knob Color
TS-A85E	2.0	BLACK
TS-A85AE	2.5	WHITE
TS-A85GE	4.0	WHITE
TS-A85CE	7.0	BLACK

PRODUCT IMAGE

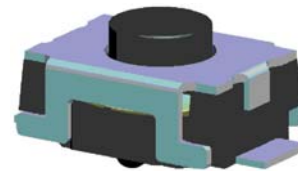

SPECIFICATIONS

Rating	DC 12V 50mA Max.			
Contact Resistance	100mΩ Max.			
Travel	0.15 ± 0.1mm			
Operating Force	2	160 ± 50gf	3	250 ± 50gf
Operating Life (cycles)	100,000			

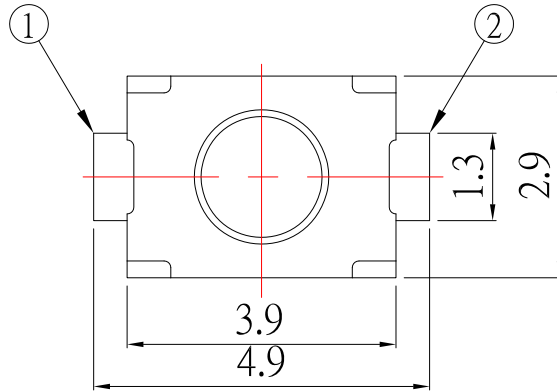
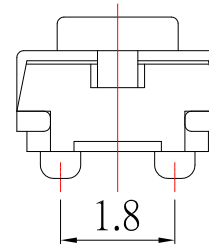
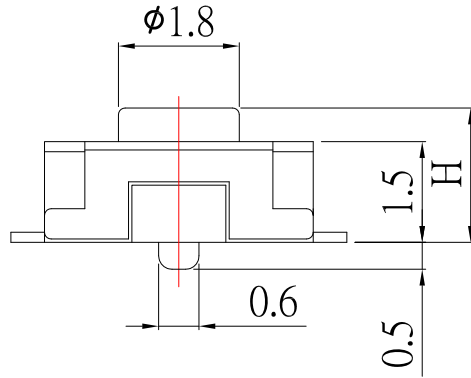

CONTACT 建倚科技股份有限公司
CONTACT TECHNOLOGY CORP.

TOLERANCE UNLESS OTHERWISE STATED:
 Up to 5 ±0.2
 Above 5 ~ 15 ±0.3
 Above 15 ~ 30 ±0.4
 Above 30 ~ 50 ±0.5
 Angle ±0.3°

3RD. ANGEL'S



UNITS MM

DRAWN BY: Jack Lu
 CHECKED BY: Jacky Chen
 APPROVED BY: Tony Kao

DATE: 12/11/14
 DATE: 12/11/14
 DATE: 12/11/14

MAT'L	TITLE	SWITCH
FINISH	MODLE	TACT SWITCH
SCALE	1 : 1	DWG NO. TS-A85xE-x-s126
SHEET NO.	1 of 1	PART NO. TS-A85xE-x-s126

ITEM NO.	DESCRIPTION	DRAWN	DATE
3	更新尺寸及Travel	Jack	121114
2	删除1.80高度选项	Jack	110714
1	更新Travel	Jack	123113

SIZE A4
 VER A0