

P.C.B LAYOUT
BOTTOM VIEW

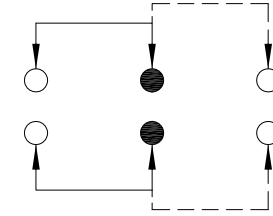

SCHEMATIC (NON-SHORTING)

Model No.	X(mm)
SK-22D03-G2	2mm
SK-22D03-G3	3mm
SK-22D03-G4	4mm
SK-22D03-G5	5mm
SK-22D03-G6	6mm
SK-22D03-G7	7mm
SK-22D03-G8	8mm
SK-22D03-G9	9mm

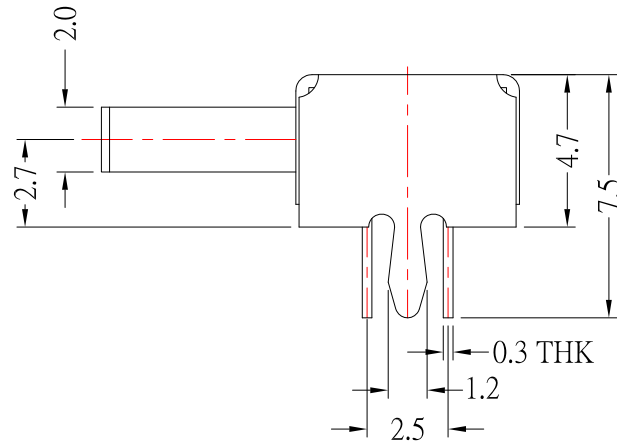
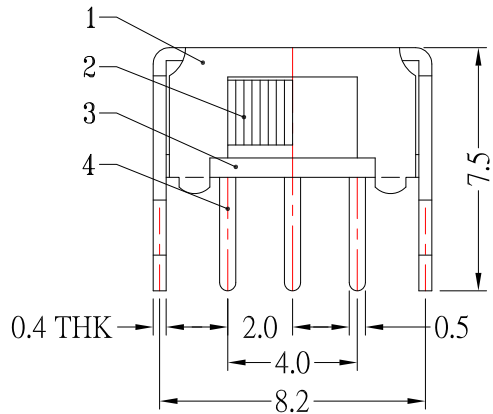

SPECIFICATIONS

Rating	0.3A 50V DC
FUNCTION	2P2T
Contact Resistance	200mΩ Max.
Insulation Resistance	100MΩ Min.
Operating Force	350gf ± 100gf
Operating Life	10,000 cycle

NO.	PARTS	MATERIALS	QTY	FINISH
6	SPRING PLATE	PBS	1	NATURAL
5	CONTACT CLIP	PBS	2	Ag PLATED
4	TERMINAL	BRASS	6	Ag PLATED
3	BASE	PHENOLIC RESIN	1	NATURAL
2	KNOB	POM	1	BLACK
1	FRAME	SPCC	1	Ni PLATED

6	更新Contact Resistance	Jack	070314
5	更新SPEC及材質和電流	Jack	103113
4	新增SPEC	Jack	102913
3	更新圖面	Jack	101713
2	更新尺寸	Jack	051413
1	更新尺寸	Jack	042513
ITEM NO.	DESCRIPTION	DRAWN	DATE

CONTACT 建倚科技股份有限公司
CONTACT TECHNOLOGY CORP.

TOLERANCE UNLESS OTHERWISE STATED :

Up to 5 ±0.2
Above 5 - 15 ±0.3
Above 15 - 30 ±0.4
Above 30 - 50 ±0.5
Angle ±0.3

3RD. ANGEL'S



UNITS MM

DRAWN BY:	DATE	MAT'L	TITLE	SWITCH
Jack Lu	07/03/14			
CHECKED BY:	DATE	FINISH	MODLE	SLIDE SWITCH (Knob:2x2mm)
Jacky Chen	07/03/14			
APPROVED BY:	DATE	SCALE	DWG NO.	SK-22D03-Gx-S191
Tony Kao	07/03/14	1 : 1		
		SHEET NO.	PART NO.	SK-22D03-Gx-S191
		1 of 1		
				SIZE A4
				VER R6