

**P.C.B LAYOUT  
TOP VIEW**

**SPECIFICATION**

1. Rating : DC 20V,10.0A
2. Contact resistance :  $\leq 30m\Omega$
3. Insulation resistance :  $\geq 100M\Omega$
4. Withstand voltage : 150VAC
5. Insertion and extraction force : 3-30N
6. life test : 5,000 cycles

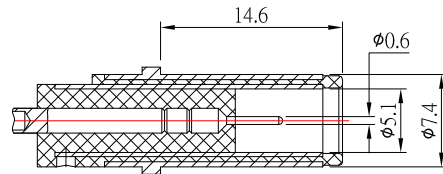
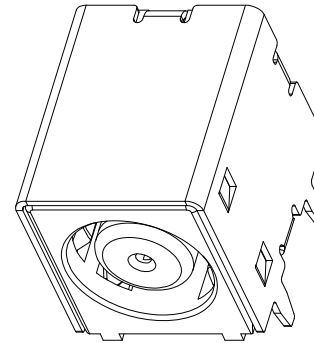
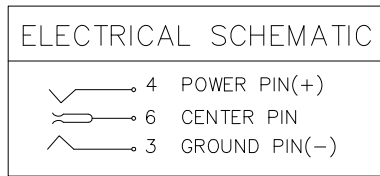
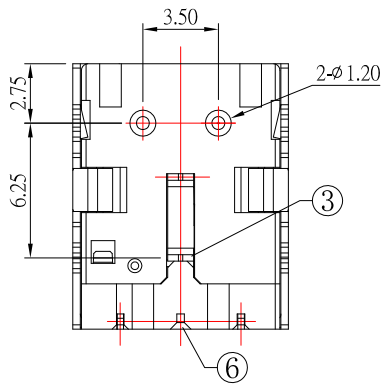

RECOMMENDED PLUG

⑥	PIN	1	PHOSPHOR BRONZE	Au-Plating
⑤	COAT	1	BRASS	Ni-Plating
④	SPRING PIECE	1	PHOSPHOR BRONZE	Au-Plating
③	SPRING PIECE	1	PHOSPHOR BRONZE	Au-Plating
②	COVER	1	LCP	
①	HOUSING	1	LCP	
NO.	DESCRIPTION	QTY	MATERIAL	PLATING

3	更新材質	Jack	111121
2	新增插入深度尺寸	Jack	050721
1	更新料號	Jack	010721
ITEM NO.	DESCRIPTION	DRAWN	DATE

**CONTACT 建倚科技股份有限公司**  
**CONTACT TECHNOLOGY CORP.**

TOLERANCE UNLESS OTHERWISE STATED :  
 Up to 5 ±0.2  
 Above 5 ~ 15 ±0.3  
 Above 15 ~ 30 ±0.4  
 Above 30 ~ 50 ±0.5  
 Angle ±0.3

3RD. ANGEL'S

UNITS MM

DRAWN BY:	DATE	MAT'L	TITLE	JACK
Jack Lu	11/11/21		MODLE	DC JACK
CHECKED BY:	DATE	FINISH	SCALE	1 : 1
Jacky Chen	11/11/21		DWG NO.	DC-093HS1-0.6-S124
APPROVED BY:	DATE	SHEET NO.	PART NO.	DC-093HS1-0.6-S124
Tony Kao	11/11/21	1 of 1		
			SIZE	A4
			VER	R3