

P.C.B LAYOUT
TOP VIEW

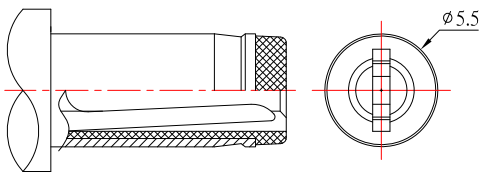
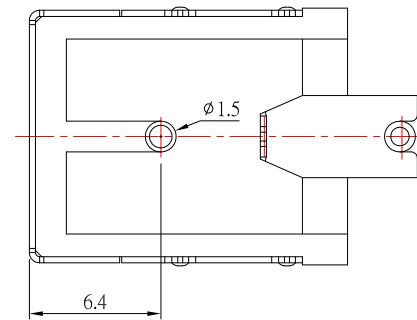
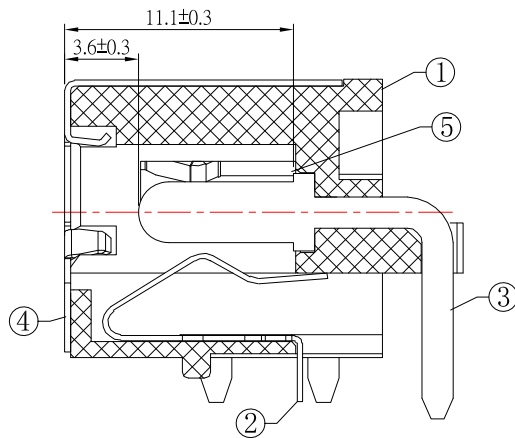

RECOMMENDED PLUG

| | | |
|-----------|--------------|--------------|
| Model NO. | DC-079HS-2.0 | DC-079HS-2.5 |
| PIN(X) | φ2.0 | φ2.5 |

| | |
|-----------|------------|
| MODEL NO. | DC-079HS-x |
| SCHEMATIC | 3 (+) |
| | 2 (-) |

SPECIFICATION

- Rating : DC 54V, 5.0A
- Contact resistance : ≤ 30mΩ
- Insulation resistance : ≥ 100MΩ
- Withstand voltage : 500VAC
- Insertion and extraction force : 5-30N
- life test : 5,000 cycles

| NO. | DESCRIPTION | QTY | MATERIAL | PLATING |
|-----|--------------|-----|-----------------|------------|
| 5 | SPRING PIECE | 1 | SUS | Sn-Plating |
| 4 | COAT | 1 | BRASS | Ni-Plating |
| 3 | PIN | 1 | BRASS | Ag-Plating |
| 2 | SPRING PIECE | 1 | PHOSPHOR BRONZE | Sn-Plating |
| 1 | HOUSING | 1 | PA9T | |

| ITEM NO. | DESCRIPTION | DRAWN | DATE |
|----------|-------------|-------|--------|
| 3 | 更新圖面 | Jack | 072023 |
| 2 | 更新Rating | Jack | 082721 |
| 1 | 更新圖面 | Jack | 083120 |

CONTACT 建倚科技股份有限公司
CONTACT TECHNOLOGY CORP.

TOLERANCE UNLESS OTHERWISE STATED :
 Up to 5 ±0.2
 Above 5 ~ 15 ±0.3
 Above 15 ~ 30 ±0.4
 Above 30 ~ 50 ±0.5
 Angle ±0.3

3RD. ANGEL'S

UNITS MM

| | | | | |
|--------------|----------|-----------|----------|-----------------|
| DRAWN BY: | DATE | MAT'L | TITLE | JACK |
| Jack Lu | 07/20/23 | | MODLE | DC JACK |
| CHECKED BY: | DATE | FINISH | SCALE | 1 : 1 |
| Jacky Chen | 07/20/23 | | DWG NO. | DC-079HS-x-S124 |
| APPROVED BY: | DATE | SHEET NO. | PART NO. | DC-079HS-x-S124 |
| Tony Kao | 07/20/23 | 1 of 1 | | |

SIZE A4
VER R3