

# SBC-WP160S2-20x-S412

鍍層厚度:

Blank	: 1u"
2	: 15u"
3	: 30u"

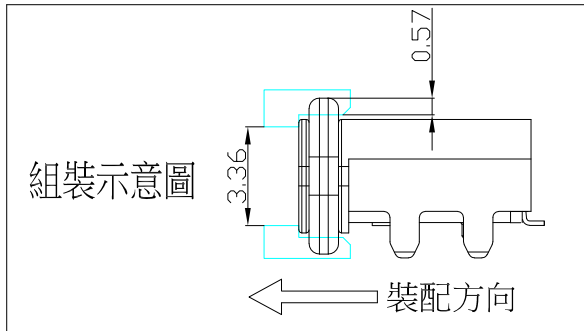
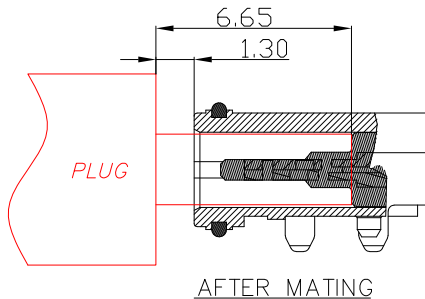

# IPX7

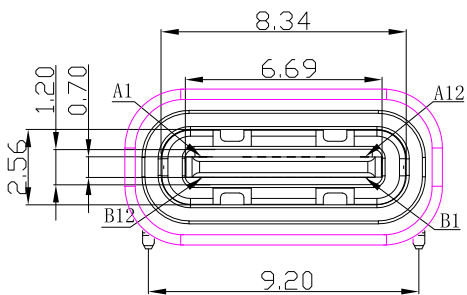
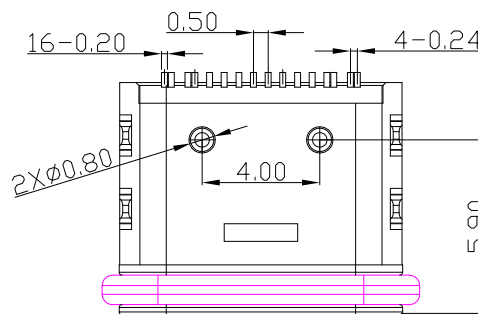
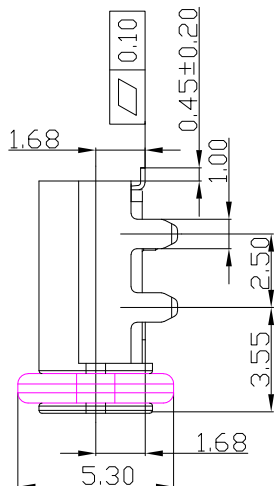
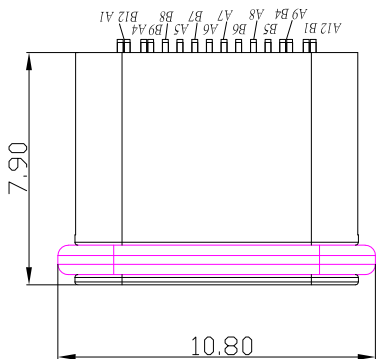
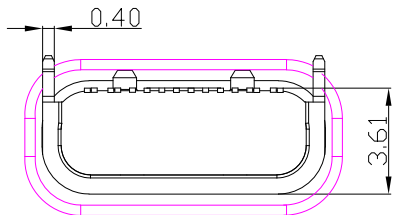
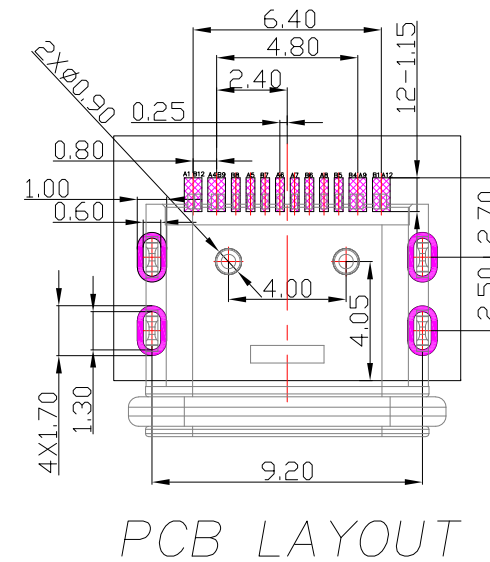

A1	GND	B12	GND
A4	VBUS	B9	VBUS
A5	CC1	B8	SBU2
A6	D+	B7	D-
A7	D-	B6	D+
A8	SBU1	B5	CC2
A9	VBUS	B4	VBUS
A12	GND	B1	GND
PIN	SIGNAL NAME	PIN	SIGNAL NAME

## SPECIFICATIONS

### Electrical:

1. Rating: 20V , 5.0 A
2. Contact Resistance: 40 mΩ Max
3. Insulation Resistance: 100 MΩ Min
4. Dielectric Withstanding Voltage: 100V AC

### Mechanical:

1. Connector Mate and Unmate Force
  - 1.1 Mate force: 5~20 N
  - 1.2 Unmate force: 8~20 N

## MATERIAL

1. Housing: PA9T
  2. Contact: C7025
  3. Shell: Zinc Alloy
- Finish:**
1. Contact: Plated Gold in Mating Area ;  
Gold Plated on Solder Balls ;  
Nickel under plated overall
  2. Shell: Nickel under Plated surface layer

**CONTACT** 建倚科技股份有限公司  
CONTACT TECHNOLOGY CORP.

TOLERANCE UNLESS OTHERWISE STATED :  
Up to 5 ±0.2  
Above 5 ~ 15 ±0.3  
Above 15 ~ 30 ±0.4  
Above 30 ~ 50 ±0.5  
Angle ±0.3

3RD. ANGEL'S

UNITS MM

DRAWN BY:	DATE	MATL	TITLE	CONNECTOR
Jack Lu	05/19/26	FINISH	MODLE	USB C TYPE 2.0 Female 防水型 防水型IPX7
CHECKED BY:	DATE	SCALE	DWG NO.	SBC-WP160S2-20x-S412
Jacky Chen	05/19/26	1 : 1	PART NO.	SBC-WP160S2-20x-S412
APPROVED BY:	DATE	SHEET NO.	1 of 1	
Tony Kao	05/19/26			

3	更新圖面	Jack	051926
2	新增對插示意圖	Jack	031924
1	新增尺寸	Jack	012624
ITEM NO.	DESCRIPTION	DRAWN	DATE