

SECTION A-A

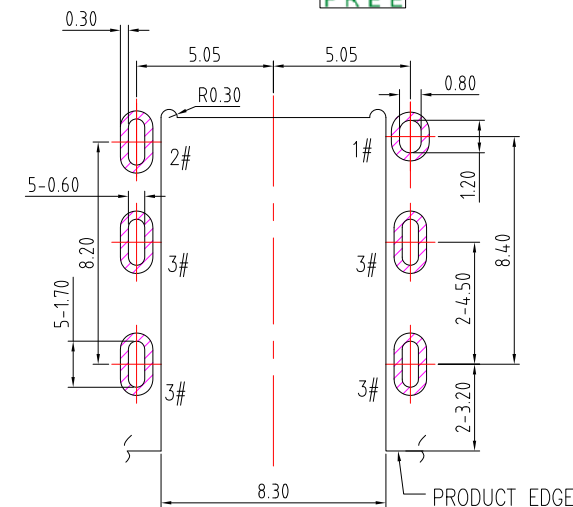

P.C.B LAYOUT
TOP VIEW

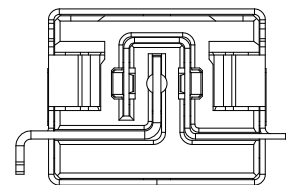
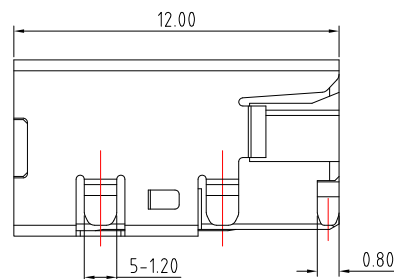
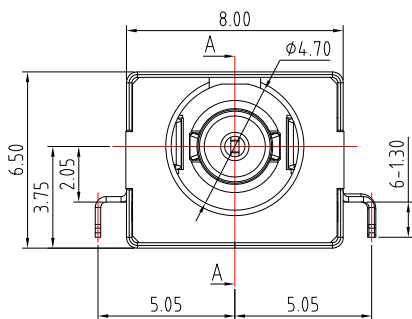
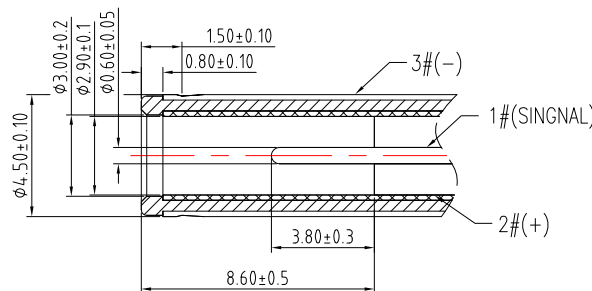
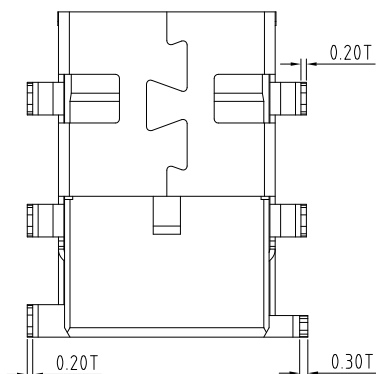

MATING PLUG

SPECIFICATION

1. Rating : DC 20V, 8.0A ;
2. Contact resistance : $\leq 30m\Omega$;
3. Insulation resistance : $\geq 100M\Omega$;
4. Withstand voltage : 500VAC ;
5. Insertion and extraction force : 6-30N ;
6. Life test : 5,000 cycles °

MODEL NO.	DC-S456H-0.6-HF
SCHEMATIC	

NO.	DESCRIPTION	QTY	MATERIAL	PLATING
4	SHELL	1	BRASS	Ni-Plating
3	SPRING	1	PHOSPHOR BRONZE	Au/Sn-Plated over Ni
2	CENTER PIN	1	PHOSPHOR BRONZE	Au/Sn-Plated over Ni
1	HOUSING	1	PA9T (BLACK)	

CONTACT 建倚科技股份有限公司
CONTACT TECHNOLOGY CORP.

TOLERANCE UNLESS OTHERWISE STATED:
 Up to 5 ± 0.2
 Above 5 ~ 15 ± 0.3
 Above 15 ~ 30 ± 0.4
 Above 30 ~ 50 ± 0.5
 Angle ± 0.3°

3RD. ANGEL'S

UNITS MM

DRAWN BY:	DATE	MAT'L	TITLE	JACK
Jack Lu	09/26/22		MODLE	DC JACK
CHECKED BY:	DATE	SCALE	DWG NO.	DC-S456H-0.6-HF-S214
Jacky Chen	09/26/22	1 : 1	PART NO.	DC-S456H-0.6-HF-S214
APPROVED BY:	DATE	SHEET NO.	SIZE	A4
Tony Kao	09/26/22	1 of 1	VER	R