

P.C.B LAYOUT  
TOP VIEW

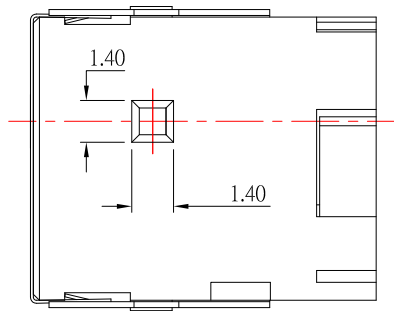
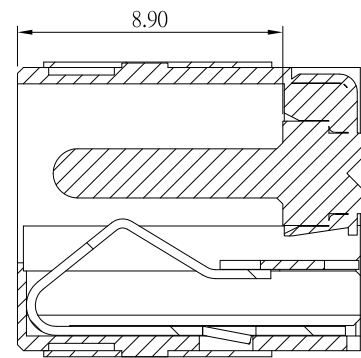

SPECIFICATION

1. Rating : DC 20V 5.0A
2. Contact resistance : ≤30mΩ
3. Insulation resistance : ≥100MΩ
4. Withstand voltage : 500VAC
5. Insertion and extraction force : 3-30N
6. life test : 10,000 cycles

MODEL NO.	DC-D044B-x
SCHEMATIC	
CENTER PIN(X)	φ1.65 mm
	φ2.0 mm
	φ2.5 mm

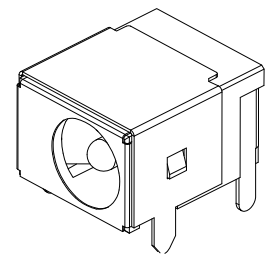

NO.	DESCRIPTION	QTY	MATERIAL	PLATING
6	COVER	1	SUS	Ni-Plating
5	PIN	1	H59	Ni-Plating
4	CONTACT FOOT	1	BRASS	Tin / Ni-Plating
3	CURVE PIECE	1	BRASS	Tin / Ni-Plating
2	SPRING PIECE	1	C17200	Tin / Ni-Plating
1	HOUSING	1	PA9T	Black

**CONTACT** 建倚科技股份有限公司  
CONTACT TECHNOLOGY CORP.

TOLERANCE UNLESS OTHERWISE STATED :  
 Up to 5 ±0.2  
 Above 5 ~ 15 ±0.3  
 Above 15 ~ 30 ±0.4  
 Above 30 ~ 50 ±0.5  
 Angle ±0.3

3RD. ANGEL'S  
  
 UNITS MM

DRAWN BY:	DATE	MAT'L	TITLE	JACK
Jack Lu	04/25/18		MODLE	DC JACK
CHECKED BY:	DATE	FINISH	SCALE	1 : 1
Jacky Chen	04/25/18		DWG NO.	DC-D044B-x-S214
APPROVED BY:	DATE	SHEET NO.	PART NO.	DC-D044B-x-S214
Tony Kao	04/25/18	1 of 1		

ITEM NO.	DESCRIPTION	DRAWN	DATE
1	更新圖面尺寸	Jack	042518