

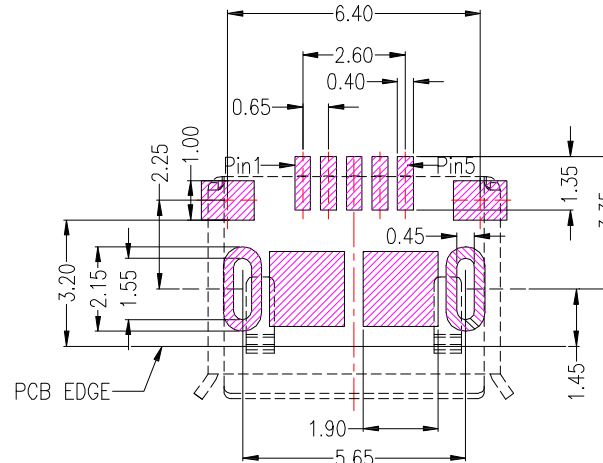

MRUSB-5B-D5x-S347

SHELL 鍍層:

TN
NI

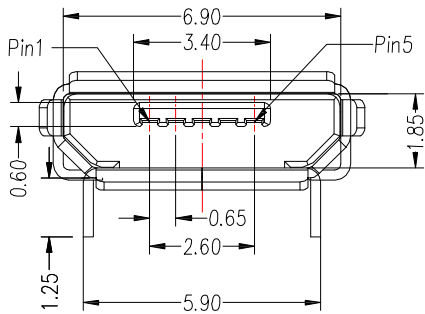
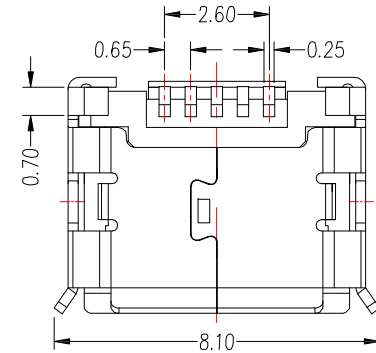
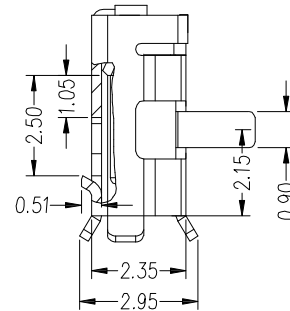
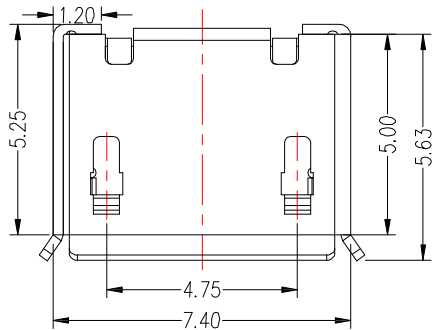
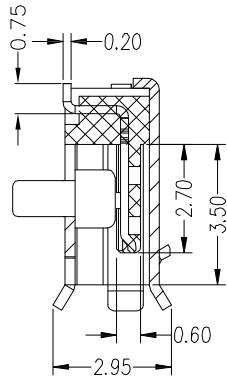
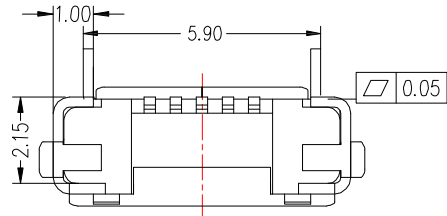

P.C.B LAYOUT MOUNTING PATTERN

NOTES:

MATERIAL:

- 1.1 HOUSING: LCP,UL94V-0
- 1.2 CONTACT: COPPER ALLOY
- 1.3 SHELL: COPPER ALLOY

Finish:

- 2.1 Contact: Plated Gold in Mating Area ;
Gold Plated on Solder Balls
Nickel under plated overall
- 2.2 Shell: Nickel or Tin under Plated surface layer

3.SPECIFICATION:

- 3.1 CURRENT RATING: 1.0 A
- 3.2 DIELECTRIC WITHSTANDING VOLTAGE: 100 V(ac) FOR 1min
- 3.3 CONTACT RESISTANCE: 50 mΩ MAX.
- 3.4 INSULATION RESISTANCE: 100 MΩ MIN.
- 3.5 TOTAL MATING FORCE: 3.57 Kgf MAX.
- 3.6 TOTAL UNMATING FORCE: 1.0 Kgf MIN.
- 3.7 TEMPERATURE RANGE: -30°C ~ +80°C

CONTACT 建倚科技股份有限公司
CONTACT TECHNOLOGY CORP.

TOLERANCE UNLESS OTHERWISE STATED:
Up to 5 ±0.2
Above 5 ~ 15 ±0.3
Above 15 ~ 30 ±0.4
Above 30 ~ 50 ±0.5
Angle ±0.3°

3RD. ANGEL'S



UNITS MM

DRAWN BY: Jack Lu
CHECKED BY: Jacky Chen
APPROVED BY: Tony Kao

DATE: 07/08/20
DATE: 07/08/20
DATE: 07/08/20

MAT'L		TITLE	CONNECTOR
FINISH		MODLE	MICRO USB 5BF 前插 (5.65)後貼無柱
SCALE	1 : 1	DWG NO.	MRUSB-5B-D5x-S347
SHEET NO.	1 of 1	PART NO.	MRUSB-5B-D5x-S347

2	新增尺寸	Jack	070820
1	更新底部樣式	Jack	022719
ITEM NO.	DESCRIPTION	DRAWN	DATE