

P.C.B LAYOUT
TOP VIEW

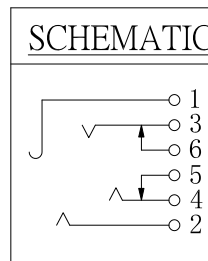
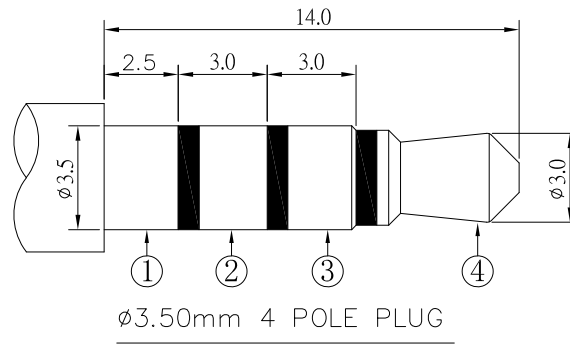
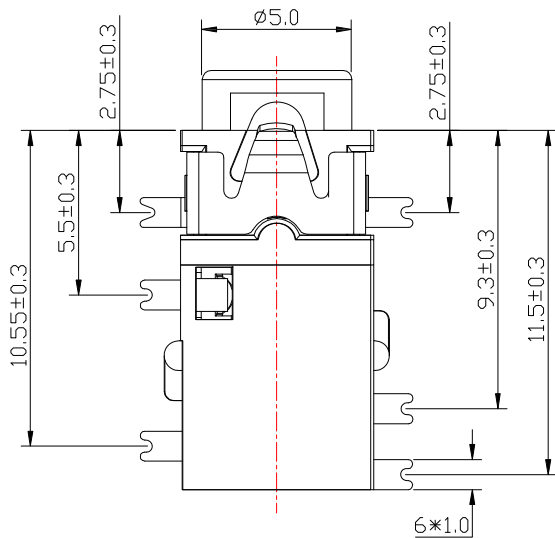

SPECIFICATION

- 1.Rating : DC 30V, 1.0A ;
- 2.Contact resistance : ≤ 30mΩ ;
- 3.Insulation resistance : ≥ 100MΩ ;
- 4.Withstand voltage : 500VAC ;
- 5.Insertion and extraction force : 3-30N;
- 6.life test : 5,000 cycles °

NO.	DESCRIPTION	QTY	MATERIAL	PLATING
⑦	HOUSING	1	PA9T	
⑥	6# CONTACT FOOT	1	PHOSPHOR BRONZE	Au Plated over Ni
⑤	5# CONTACT FOOT	1	PHOSPHOR BRONZE	Au Plated over Ni
④	4# CONTACT FOOT	1	PHOSPHOR BRONZE	Au Plated over Ni
③	3# CONTACT FOOT	1	PHOSPHOR BRONZE	Au Plated over Ni
②	2# CONTACT FOOT	1	PHOSPHOR BRONZE	Au Plated over Ni
①	1# CONTACT FOOT	1	PHOSPHOR BRONZE	Au Plated over Ni

ITEM NO.	DESCRIPTION	DRAWN	DATE
8	更新圖面	Jack	090224
7	更新圖面	Jack	072123
6	更新電路選項	Jack	042922
5	新增PLUG標號	Jack	052819
4	更新圖面	Jack	052419

CONTACT 建倚科技股份有限公司
CONTACT TECHNOLOGY CORP.

TOLERANCE UNLESS OTHERWISE STATED :
 Up to 5 ±0.2
 Above 5 ~ 15 ±0.3
 Above 15 ~ 30 ±0.4
 Above 30 ~ 50 ±0.5
 Angle ±0.3

3RD. ANGEL'S

UNITS MM

DRAWN BY:	DATE	MAT'L	TITLE	JACK
Jack Lu	09/02/24			
CHECKED BY:	DATE	FINISH	MODLE	PHONE JACK
Jacky Chen	09/02/24			
APPROVED BY:	DATE	SCALE	DWG NO.	PJ-S3118-S124
Tony Kao	09/02/24	1 : 1		
SHEET NO.	1 of 1	PART NO.	PJ-S3118-S124	
				SIZE A4
				VER R8