

**PCB LAYOUT
TOP VIEW**

SPECIFICATION

1. Rating : DC 24V 5.0A ;
2. Contact resistance : $\leq 30m\Omega$;
3. Insulation resistance : $\geq 100M\Omega$;
4. Withstand voltage : 500VAC ;
5. Insertion force : 3-30N;
extraction force : 3-30N;
6. life test : 5,000 cycles .

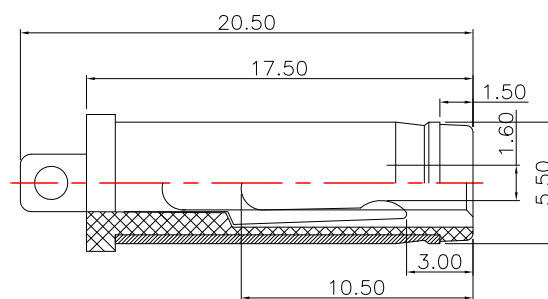
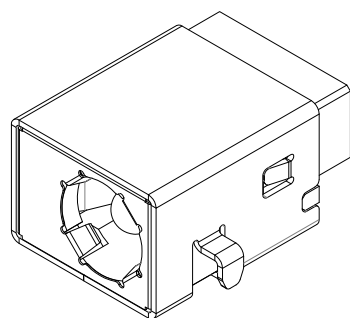

MATING PLUG $\phi 5.50$

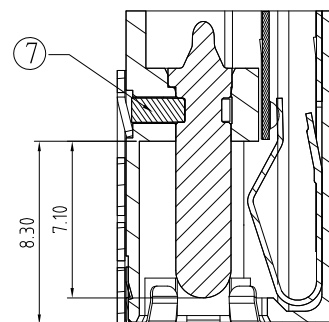

Model No.	DC-D303-x
SCHEMATIC	4 CENTER PIN (+)
	3 CONTACT FOOT
CENTER PIN	2 TIP SPRING (-)
	$\phi 2.00$ mm
	$\phi 2.50$ mm

NO.	DESCRIPTION	QTY	MATERIAL	PLATING
⑦	STOPPER	1	SUS	
⑥	SHELL	1	BRASS	Ni-Plating
⑤	GROUND	1	SUS	
④	PIN	1	BRASS	Ni-Plating
③	CONTACT FOOT	1	BRASS	Ni-Plating
②	SPRING	1	PHOSPHOR BRONZE	Ni-Plating
①	HOUSING	1	LCP	Black

CONTACT 建倚科技股份有限公司
CONTACT TECHNOLOGY CORP.

TOLERANCE UNLESS OTHERWISE STATED:
 Up to 5 ±0.2
 Above 5 ~ 15 ±0.3
 Above 15 ~ 30 ±0.4
 Above 30 ~ 50 ±0.5
 Angle ±0.3

3RD. ANGEL'S UNITS MM

DRAWN BY:	DATE	MAT'L	TITLE	JACK
Jack Lu	03/07/18		MODLE	DC JACK
CHECKED BY:	DATE	FINISH	SCALE	1 : 1
Jacky Chen	03/07/18		DWG NO.	DC-D303-x-S214
APPROVED BY:	DATE	SHEET NO.	PART NO.	DC-D303-x-S214
Tony Kao	03/07/18	1 of 1		

ITEM NO.	DESCRIPTION	DRAWN	DATE

SIZE A4
VER R