

**SPECIFICATION**

1. Rating : 0.5A , 30VDC ;
2. Contact resistance :  $\leq 50m\Omega$  ;
3. Insulation resistance :  $\geq 100M\Omega$  ;
4. Withstand voltage : 500VAC ;
5. life test : 5,000 cycles .
6. Connector mating forces : 20N (2.04Kgf) Max ;
7. Connector unmating forces : 2N(0.204Kgf) Min .

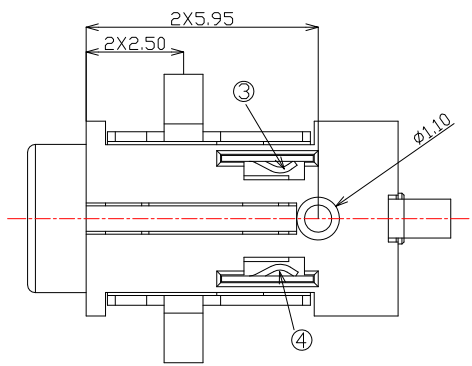
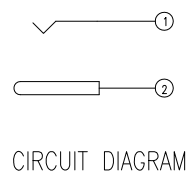

ITEM	NAME	Q'TY	MATERIAL	DESCRIPTION
7	MYLAR	1		
6	HOUSING	1	HTN	
5	CONTACT E	1	PHOSPHOR BRONZE	GOLD PLATED
4	CONTACT D	1	STAINLESS STEEL	
3	CONTACT C	1	STAINLESS STEEL	
2	CONTACT B	1	BRASS	GOLD PLATED
1	CONTACT A	1	PHOSPHOR BRONZE	GOLD PLATED

**CONTACT** 建倚科技股份有限公司  
**CONTACT TECHNOLOGY CORP.**

TOLERANCE UNLESS OTHERWISE STATED :  
 Up to 5 ±0.2  
 Above 5 ~ 15 ±0.3  
 Above 15 ~ 30 ±0.4  
 Above 30 ~ 50 ±0.5  
 Angle ±0.3

3RD. ANGEL'S

UNITS MM

DRAWN BY:	DATE	MAT'L	TITLE	JACK
Jack Lu	08/04/15	FINISH	MODLE	DC JACK
CHECKED BY:	DATE	SCALE	DWG NO.	DC-063DS-S119
Jacky Chen	08/04/15	SHEET NO.	PART NO.	DC-063DS-S119
APPROVED BY:	DATE			
Tony Kao	08/04/15			

ITEM NO.	DESCRIPTION	DRAWN	DATE
3	新增SPEC	Jack	080415
2	更新材質	Jack	042214
1	圖面更新	FrankWu	112811