

P.C.B LAYOUT
TOP VIEW

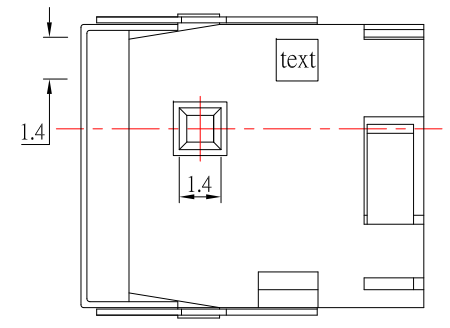
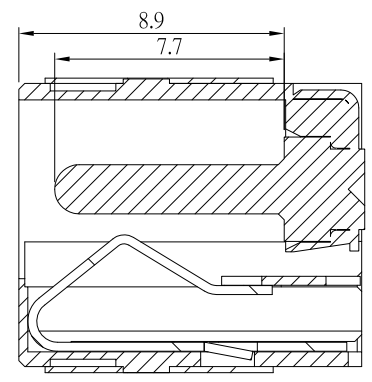

SPECIFICATION

- 1. Rating : DC 20V 5.0A
- 2. Contact resistance : $\leq 30m\Omega$
- 3. Insulation resistance : $\geq 100M\Omega$
- 4. Withstand voltage : 500VAC
- 5. Insertion and extraction force : 3-30N
- 6. life test : 5,000 cycles

MODEL NO.	DC-048HS5-1.65
SCHMATIC	

7	COVER	1	SUS	Ni-Plating
6	CONTACT FOOT	1	BRASS	Tin-Plating
5	PIN	1	BRASS	Ni-Plating
4	CONTACT FOOT	1	BRASS	Ag-Plating
3	CURVE PIECE	1	BRASS	Ag-Plating
2	SPRING PIECE	1	PHOSPHOR BRONZE	Ag-Plating
1	HOUSING	1	PA9T	Black
NO.	DESCRIPTION	QTY	MATERIAL	PLATING

10	更新樣式	Ian	041719
9	新增尺寸	Jack	100418
8	更新料號	Jack	050318
7	更新材質及鍍層	Jack	080417
6	更新life test	Jack	072817
5	更新圖面樣式	Jack	051017
4	新增PLUG圖示	Jack	011017
3	更新腳位編號	Jack	010617
2	更新為A0版	Jack	060816
1	更新Rating	Jack	121515
ITEM NO.	DESCRIPTION	DRAWN	DATE

13	更新料號	Jack	061821
12	新增尺寸	Jack	103019
11	更新MODLE	Jack	073119

CONTACT 建倚科技股份有限公司
CONTACT TECHNOLOGY CORP.

TOLERANCE UNLESS OTHERWISE STATED :
 Up to 5 ±0.2
 Above 5 ~ 15 ±0.3
 Above 15 ~ 30 ±0.4
 Above 30 ~ 50 ±0.5
 Angle ±0.3

3RD. ANGEL'S

UNITS MM

DRAWN BY:	DATE	MAT'L	TITLE	JACK
Jack Lu	06/18/21			
CHECKED BY:	DATE	FINISH	MODLE	DC JACK 高電流 / 帶彈片帶外殼
Jacky Chen	06/18/21			
APPROVED BY:	DATE	SCALE	DWG NO.	DC-048HS5-1.65-S214
Tony Kao	06/18/21	1 : 1		
		SHEET NO.	PART NO.	DC-048HS5-1.65-S214
		1 of 1		
			SIZE	A4
			VER	R13