

PCB LAYOUT
(BOTTOM VIEW)

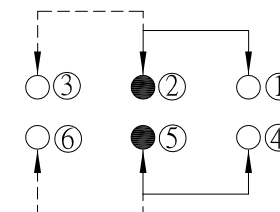

SCHEMATIC(NON-SHORTING)

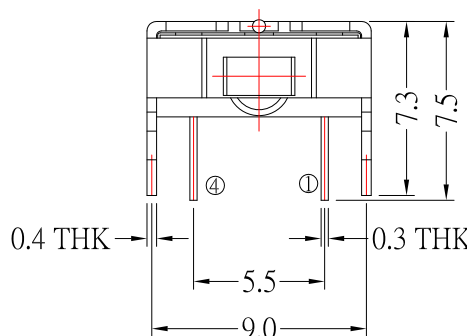
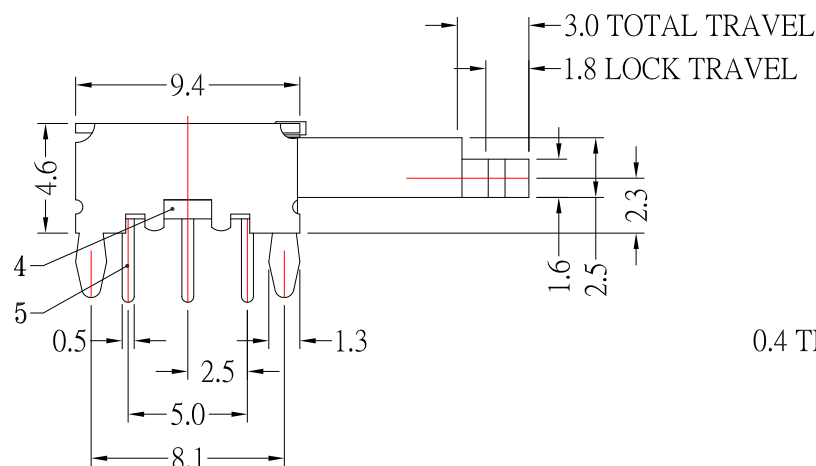

SPECIFICATIONS

1. Rating : DC 30V, 0.5A
2. Circuit : 2P2T
3. Timing : Non-Shorting
4. Operating force : 250 ± 100gf
5. Life test : 10,000 cycles
6. Operating Mode : Self-Lock

NO.	PARTS	MATERIALS	Q'TY	FINISH
8	CONTACT CLIP	PBS STRIP	2	Ag PLATED
7	CAM STICK	BRASS WIRE	1	NATURAL
6	SPRING PLATE	PBS STRIP	1	NATURAL
5	TERMINAL	BRASS STRIP	6	Ag PLATED
4	BASE	PHENOLIC RESIN	1	NATURAL
3	FRAME	STEEL STRIP	1	Ni PLATED
2	SPRING	STEEL WIRE	1	NATURAL
1	KNOB	POM	1	YELLOW

ITEM NO.	DESCRIPTION	DRAWN	DATE
4	更新圖面	Jack	060220
3	新增SPEC	Jack	102615
2	新增PIN編號	Jack	112614
1	新增Operating Mode	Jack	072514

CONTACT 建倚科技股份有限公司
CONTACT TECHNOLOGY CORP.

TOLERANCE UNLESS OTHERWISE STATED :
 Up to 5 ±0.2
 Above 5 ~ 15 ±0.3
 Above 15 ~ 30 ±0.4
 Above 30 ~ 50 ±0.5
 Angle ±0.3

3RD. ANGEL'S

UNITS MM

DRAWN BY:	DATE	MAT'L	TITLE	SWITCH
Jack Lu	06/02/20	FINISH	MODLE	PUSH SWITCH 黃色柄
CHECKED BY:	DATE	SCALE	DWG NO.	PS-22E02-S191
Jacky Chen	06/02/20	SHEET NO.	PART NO.	PS-22E02-S191
APPROVED BY:	DATE			
Tony Kao	06/02/20			