

CIRCUIT DIAGRAM

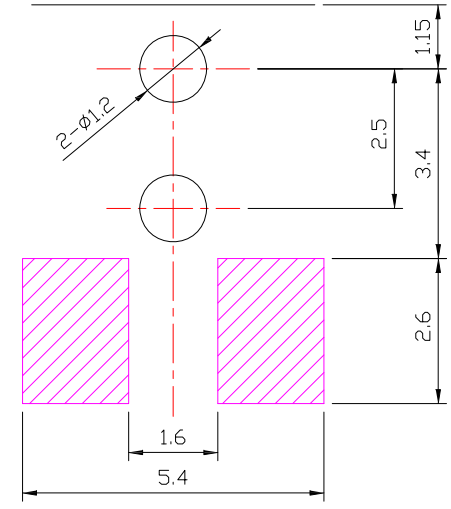

P.C.B LAYOUT

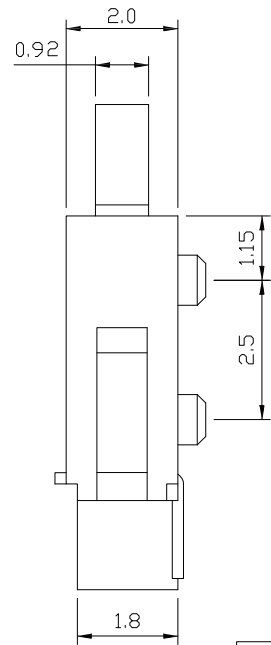
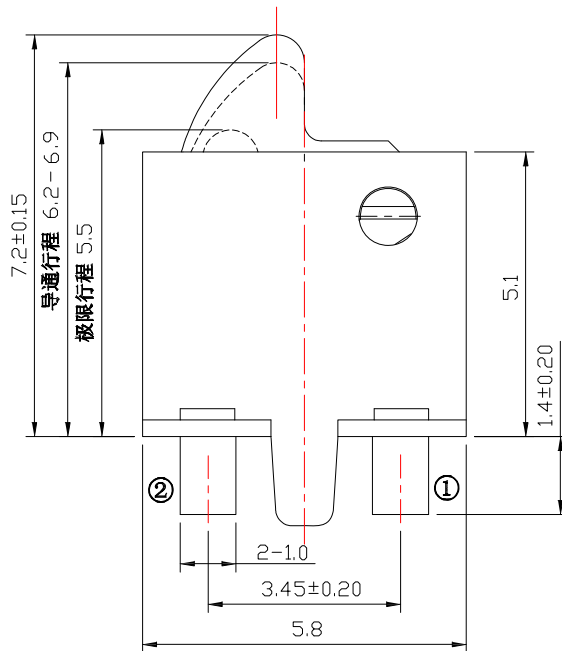

SPECIFICATIONS

Rating	DC 12V, 0.1A.
Contact Resistance	200mΩ Max.
Insulation Resistance	50MΩ Min.
Operating Force	20±10 gf
Mechanical Life	30,000 cycles

4	TERMINAL	BRASS	2	Ag PLATED
3	SPRING	PHOSPHOR BRONZE	1	Ag PLATED
2	BASE	PA46(BLACK)	1	
1	KNOB	PA46(BLACK)	1	
NO	NAME	MATERIAL	QTY	FINISHING

**CONTACT** 建倚科技股份有限公司  
CONTACT TECHNOLOGY CORP.

TOLERANCE UNLESS OTHERWISE STATED:  
 Up to 5 ±0.2  
 Above 5 ~ 15 ±0.3  
 Above 15 ~ 30 ±0.4  
 Above 30 ~ 50 ±0.5  
 Angle ±0.3

3RD. ANGEL'S



UNITS

MM

DRAWN BY:	DATE	MAT'L	TITLE	SWITCH
Jack Lu	01/12/22			
CHECKED BY:	DATE	FINISH	MODLE	DETECTOR SWITCH
Jacky Chen	01/12/22			
APPROVED BY:	DATE	SCALE	DWG NO.	DS-A50-S379
Tony Kao	01/12/22	1 : 1		
		SHEET NO.	PART NO.	DS-A50-S379
		1 of 1		

1	更新圖面	Jack	011222
ITEM NO.	DESCRIPTION	DRAWN	DATE