

P.C.B LAND PATTERN

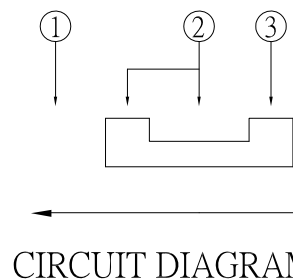

CIRCUIT DIAGRAM

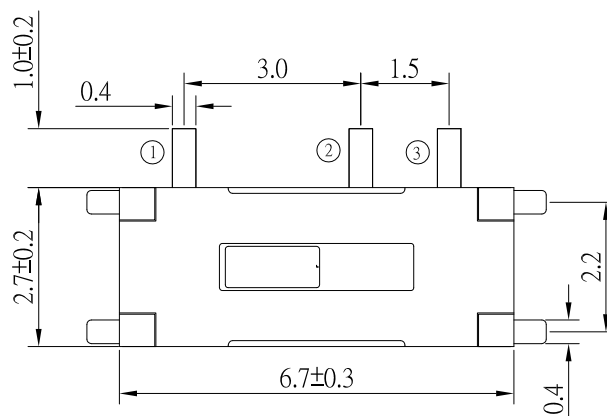
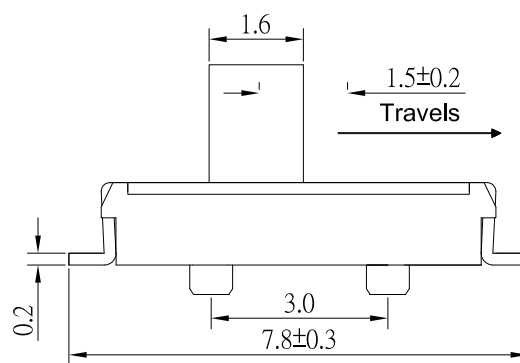
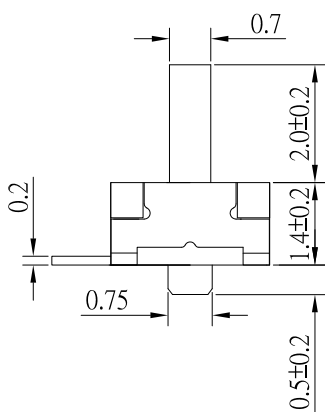

SPECIFICATIONS

Rating	0.3A 4V DC
Insulation Resistance	100MΩ Min.
Dielectric Withstanding Voltage	AC 250 V(50Hz)1min
Contact Resistance	100mΩ Max.
Operating Force	160 ± 50gf
Operating Life	10,000 cycles

NO.	DESCRIPTION	QTY	MATERIAL	PLATING
F	CONTACT	1	PHOSPHOR BRONZE	Ag plated
E	TERMINAL	3	PHOSPHOR BRONZE	Ag plated
D	CLIP	1	SUS	
C	COVER	1	BRASS	Ag plated
B	CASE	1	LCP(Black)	
A	SLIDER	1	PPA(White)	

ITEM NO.	DESCRIPTION	DRAWN	DATE
8	更新材質	Jack	012921
7	更新圖面	Jack	040919
6	更新材質	Jack	101217
5	更新材質	Jack	090817
4	更新Rating	Jack	080117
3	更新料號	Jack	091916
2	更新料號	Jack	070413
1	更新Rating	Jack	062813

**CONTACT** 建倚科技股份有限公司  
**CONTACT TECHNOLOGY CORP.**

TOLERANCE UNLESS OTHERWISE STATED:  
 Up to 5 ±0.2  
 Above 5 ~ 15 ±0.3  
 Above 15 ~ 30 ±0.4  
 Above 30 ~ 50 ±0.5  
 Angle ±0.3

3RD. ANGEL'S



UNITS MM

DRAWN BY:	DATE	MAT'L	TITLE	SWITCH
Jack Lu	01/29/21		MODLE	SMT SLIDE SWICTH 平柄 柄寬:1.6*2.0
CHECKED BY:	DATE	FINISH	SCALE	1 : 1
Jacky Chen	01/29/21		DWG NO.	SS-B95A-W-S246
APPROVED BY:	DATE	SHEET NO.	PART NO.	SS-B95A-W-S246
Tony Kao	01/29/21	1 of 1	SIZE	A4
			VER	R8