

CIRCUIT DIAGRAM

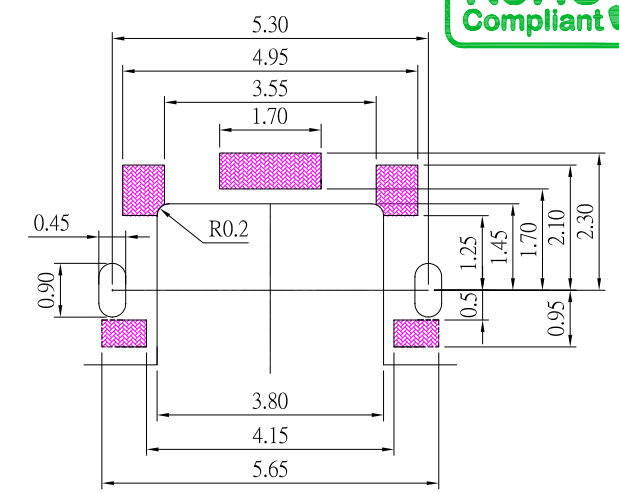

P.C.B LAND PATTERN

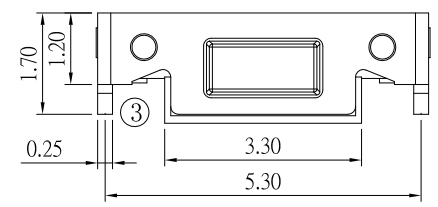
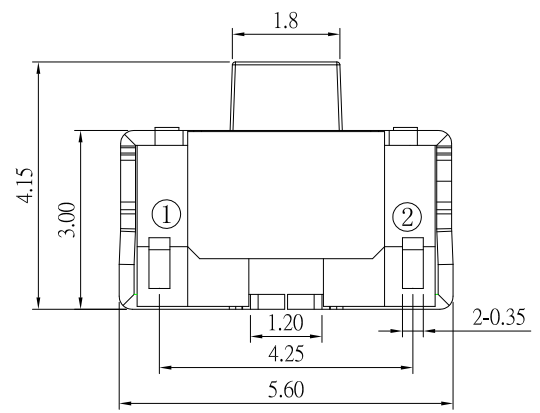
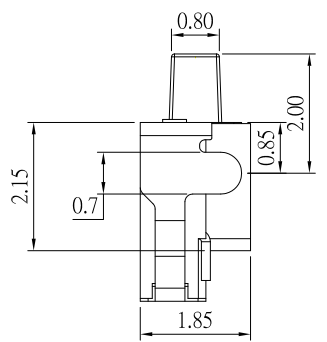

SPECIFICATIONS

Rating	0.05A 12V DC
Insulation Resistance	50MΩ Min.
Dielectric Withstanding Voltage	AC 250 V(50Hz)1min
Contact Resistance	100mΩ Max.
Operating Force	180 ± 30gf
Operating Life	100,000 cycles

NO.	DESCRIPTION	QTY	MATERIAL	PLATING
E	THERMINAL	2	PHOSPHOR BRONZE	Ag plated
D	CONTACT	3	STAINLESS STEEL	Ag plated
C	COVER	1	PHOSPHOR BRONZE	
B	BASE	1	LCP	Black
A	STEM	1	LCP	Black

**CONTACT** 建倚科技股份有限公司  
**CONTACT TECHNOLOGY CORP.**

TOLERANCE UNLESS OTHERWISE STATED:  
 Up to 5 ±0.2  
 Above 5 ~ 15 ±0.3  
 Above 15 ~ 30 ±0.4  
 Above 30 ~ 50 ±0.5  
 Angle ±0.3°

3RD. ANGEL'S UNITS MM

DRAWN BY:	DATE	MAT'L	TITLE	SWITCH
Jack Lu	11/07/13			
CHECKED BY:	DATE	FINISH	MODLE	TACT SWITCH
Jacky Chen	11/07/13			
APPROVED BY:	DATE	SCALE	DWG NO.	TS-A28- 2-S246
Tony Kao	11/07/13	1 : 1		
		SHEET NO.	PART NO.	TS-A28- 2-S246
		1 of 1		

ITEM NO.	DESCRIPTION	DRAWN	DATE