

CIRCUIT DIAGRAM

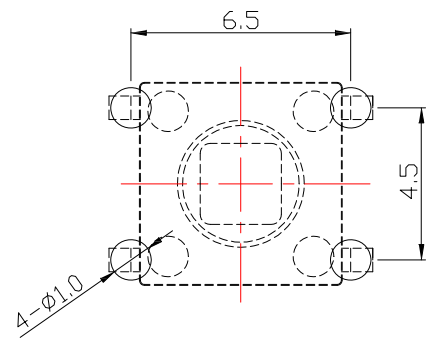
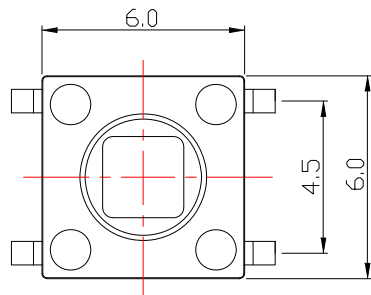

P.C.B LAYOUT MOUNTING PATTERN

SPECIFICATIONS

Rating	DC 12V 50mA Max.
Contact Resistance	100mΩ Max.
Travel	0.25 ± 0.1mm
Operating Force	2 160 ± 50gf 3 250 ± 50gf
Operating Life (cycle)	100,000 cycles

CONTACT 建倚科技股份有限公司
CONTACT TECHNOLOGY CORP.

TOLERANCE UNLESS OTHERWISE STATED:
 Up to 5 ±0.2
 Above 5 ~ 15 ±0.3
 Above 15 ~ 30 ±0.4
 Above 30 ~ 50 ±0.5
 Angle ±0.3

3RD. ANGEL'S

UNITS MM

DRAWN BY:	DATE	MAT'L	TITLE	SWITCH
Jack Lu	01/12/15			
CHECKED BY:	DATE	FINISH	MODLE	TACT SWITCH
Jacky Chen	01/12/15			
APPROVED BY:	DATE	SCALE	DWG NO.	TS-A02T-x-S126
Tony Kao	01/12/15	1 : 1		
		SHEET NO.	PART NO.	TS-A02T-x-S126
		1 of 1		

ITEM NO.	DESCRIPTION	DRAWN	DATE