

SECTION A-A

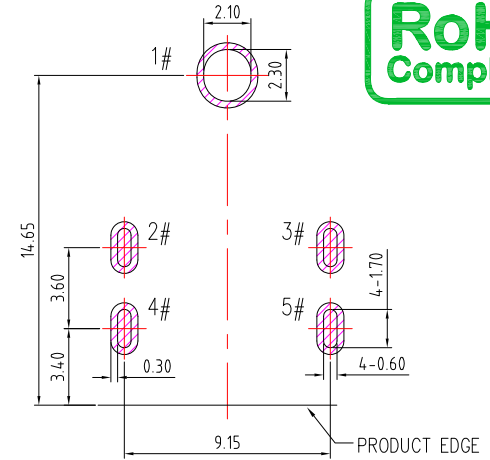

PCB LAYOUT
TOP VIEW

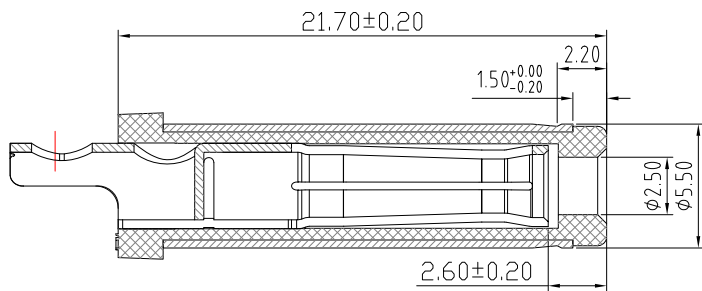
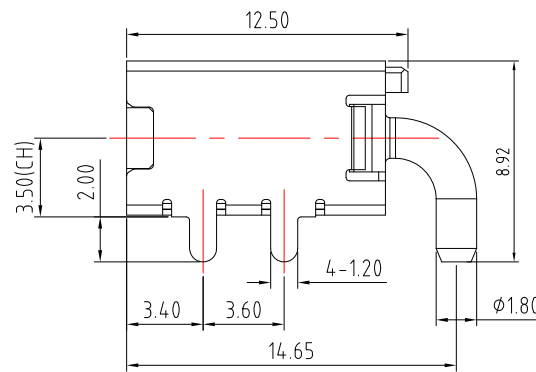
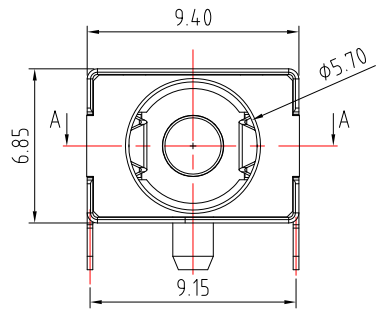

MATE PLUG

MODEL NO.	DC-D3012DH-2.5
SCHMATIC	

SPECIFICATION

1. Rating : DC 30V, 20A
2. Contact resistance : $\leq 50m\Omega$
3. Insulation resistance : $\geq 100M\Omega$
4. Withstand voltage : 500VAC
5. Insertion and extraction force : 3-30N
6. life test : 5,000 cycles

ITEM	NAME	Q'TY	DESCRIPTION
C	CONCTOR PIN	1	BRASS; GOLD PLATED OVER NICKEL
B	SHELL	1	PHOSPHOR BRONZE; NICKEL PLATED.
A	HOUSING	1	PA9T,COLOR BLACK

CONTACT 建倚科技股份有限公司
CONTACT TECHNOLOGY CORP.

TOLERANCE UNLESS OTHERWISE STATED:
 Up to 5 ±0.2
 Above 5 ~ 15 ±0.3
 Above 15 ~ 30 ±0.4
 Above 30 ~ 50 ±0.5
 Angle ±0.3°

3RD. ANGEL'S UNITS MM

DRAWN BY:	DATE	MAT'L	TITLE	JACK
Jack Lu	08/09/23	FINISH	MODLE	DC JACK 大電流
CHECKED BY:	DATE	SCALE	DWG NO.	DC-D3012DH-2.5-S457
Jacky Chen	08/09/23	1 : 1	PART NO.	DC-D3012DH-2.5-S457
APPROVED BY:	DATE	SHEET NO.	SIZE	A4
Tony Kao	08/09/23	1 of 1	VER	R

ITEM NO.	DESCRIPTION	DRAWN	DATE
A			
B			
C			
D			
E			
F			
G			
H			
I			
J			