

RECOMMENDED PCB LAYOUT

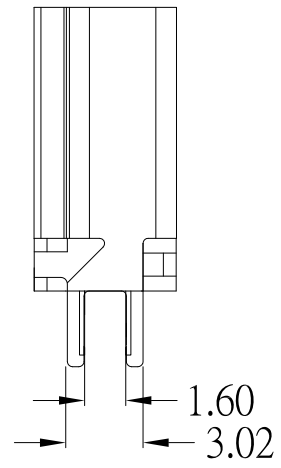
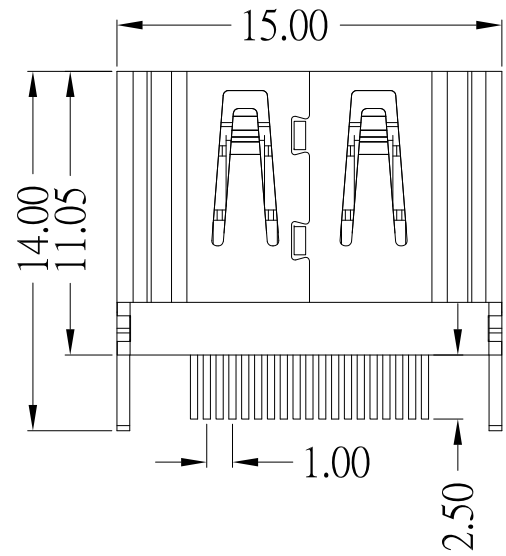

HDMI-19P-V2x-S277

SHELL MATERIAL:

X	BRASS
I	SPCC

NOTE:

- 1.MATERIAL:
 - 1.1 HOUSING: LCP,Black
 - 1.2 CONTACT: BRASS
 - 1.3 SHELL: BRASS / SPCC
- 2.PLATING :
 - 2.1 CONTACT: PLATED GOLD IN MATING AREA ;
TIN PLATED ON SOLDER BALLS ;
NICKEL UNDER PLATED OVERALL
 - 2.2 SHELL: NICKEL UNDER PLATED SURFACE LAYER
- 3.ELECTRICAL:
 - 3.1 RATING CURRENT: 0.5A
 - 3.2 CONTACT RESISTANCE: 30 mΩ Max
 - 3.3 INSULATION RESISTANCE: 100MΩ Min
 - 3.4 DIELECTRIC WITHSTANDING: 300V AC
 - 3.5 OPERATING TEMPERATURE: -20°C~ 85°C
- 4.MECHANICAL:
 - 4.1 INSERTION FORCE: 44.1 N Max
 - 4.2 EXTROCTION FORCE: 9.8 N Min

CONTACT 建倚科技股份有限公司
CONTACT TECHNOLOGY CORP.

TOLERANCE UNLESS OTHERWISE STATED
Up to 5 ±0.2
Above 5 ~ 15 ±0.3
Above 15 ~ 30 ±0.4
Above 30 ~ 50 ±0.5
Angle ±0.3°

3RD. ANGEL'S

UNITS MM

DRAWN BY:	DATE	MAT'L	TITLE	CONNECTOR
Jack Lu	09/12/23			
CHECKED BY:	DATE	FINISH	MODLE	HDMI A TYPE 母座夾板式
Jacky Chen	09/12/23			
APPROVED BY:	DATE	SCALE	DWG NO.	HDMI-19P-V2x-S277
Tony Kao	09/12/23	1 : 1		
		SHEET NO.	PART NO.	HDMI-19P-V2x-S277
		1 of 1		
				SIZE A4
				VER R3

ITEM NO.	DESCRIPTION	DRAWN	DATE
2	新增PCB LAYOUT尺寸	Jack	091223
1	更新料號和圖面	Jack	071723