



HDU2-270H-x-S373

COLOR :

White : W

Black : B

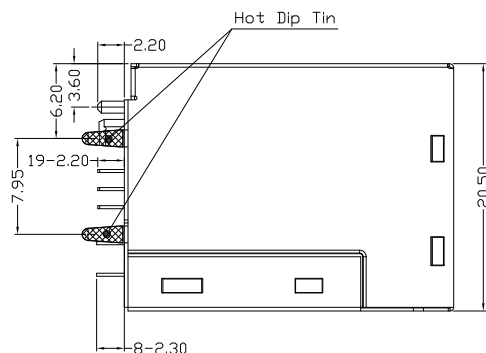
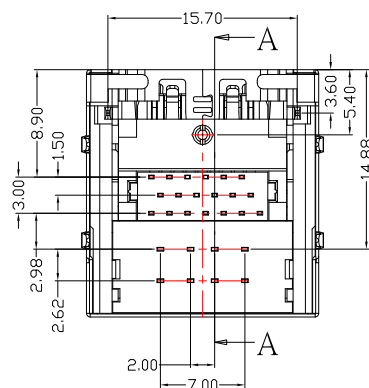
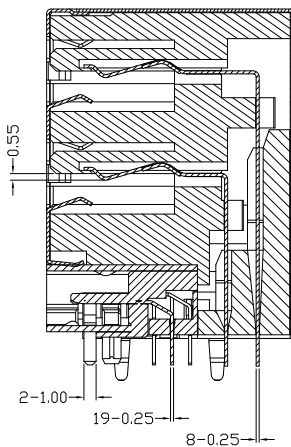
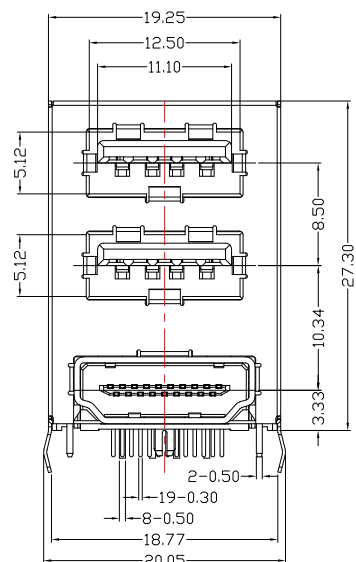
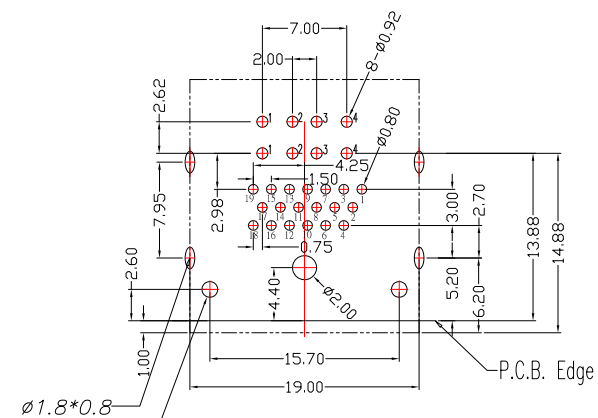

SPECIFICATIONS

- USB
 - Voltage: 250 VAC(RMS) Max.
 - Current Rating: 1.5 Ampere per Pontact
 - Contact Resistance: 30 Milliohms Max.
 - Insulation Resistance: 1000 Megohms Min.
 - Dielectric Withstanding Voltage: 750 VAC(RMS)
 - Total Mating Force: 3.57 Kgf Max.
 - Total Unmating Force: 1.02 Kgf Min.
 - Operating Temperature: -55°C to +85°C
- HDMI
 - Voltage: 40 VAC(RMS) Max.
 - Current Rating: 0.5 Ampere per Contact
 - Contact Resistance: 30 Milliohms Max.
 - Insulation Resistance: 100 Megohms Min.
 - Dielectric Withstanding Voltage: 500V DC(RMS)
 - Total Mating Force: 4.5 Kgf Max.
 - Total Unmating Force: 1.0 Kgf Min.
 - Operating Temperature: -55°C to +85°C

NOTES

- MATERIAL:
 - Housing(USB):PBT
 - Housing(HDMI):LCP
 - Terminal:Brass.
 - Shell(USB):SUS.
 - Shell(HDMI):SUS.
- FINISH:
 - Terminal:Gold Plated over Nickel at Conatct Area.
 - Tin Plated over Nickel at Solder Area.
 - Shell(USB):Nickel Plated.
 - Shell(HDMI):Nickel Plated.

CONTACT 建倚科技股份有限公司
CONTACT TECHNOLOGY CORP.

TOLERANCE UNLESS OTHERWISE STATED :

Up to 5	±0.2
Above 5 ~ 15	±0.3
Above 15 ~ 30	±0.4
Above 30 ~ 50	±0.5
Angle	±0.3°

3RD. ANGEL'S



UNITS MM

DRAWN BY:	DATE	MAT'L	TITLE	CONNECTOR
Jack Lu	05/17/22			
CHECKED BY:	DATE	FINISH	MODLE	雙層 USB 2.0 AF + HDMI AF 90 度 DIP TYPE
Jacky Chen	05/17/22			
APPROVED BY:	DATE	SCALE	DWG NO.	SIZE
Tony Kao	05/17/22	1 : 1	HDU2-270H-x-S373	A4
		SHEET NO.	PART NO.	VER
		1 of 1	HDU2-270H-x-S373	R

ITEM NO.	DESCRIPTION	DRAWN	DATE
----------	-------------	-------	------