

WITHOUT COVER

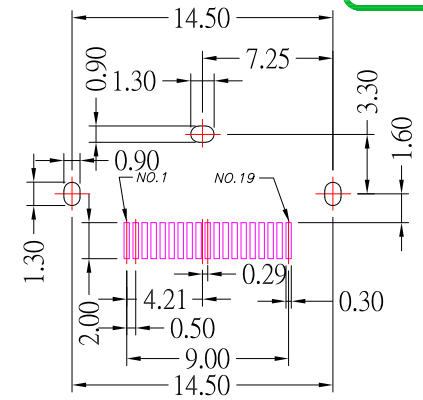

PCB LAYOUT

NOTE:

1.MATERIAL:

1.1 HOUSING: LCP , BLACK

1.2 CONTACT: BRASS

1.3 SHEEL: BRASS

2.PLATING :

2.1 CONTACT: PLATED GOLD IN MATING AREA ;
GOLD PLATED ON SOLDER BALLS ;
NICKEL UNDER PLATED OVERALL

2.2 SHELL: NICKEL UNDER PLATED SURFACE LAYER

3.ELECTRICAL:

3.1 RATING: 40V , 0.5A

3.2 INSULATION RESISTANCE: 100MΩ MIN

3.3 CONTACT RESISTANCE: 30 mΩ MAX

3.4 WITHSTANDING VOLTAGE: 500V AC / MINUTE

3.5 OPERATING TEMPERATURE: -25°C~ 85°C

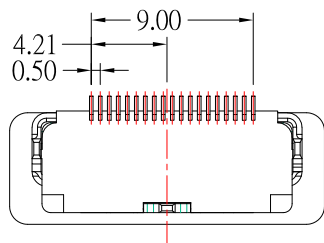
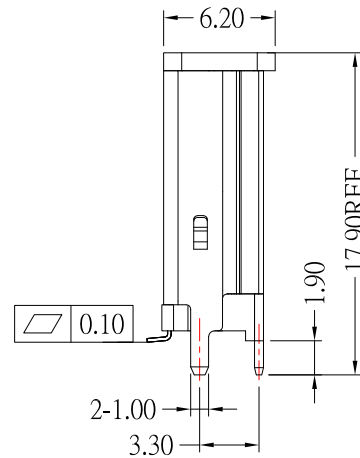
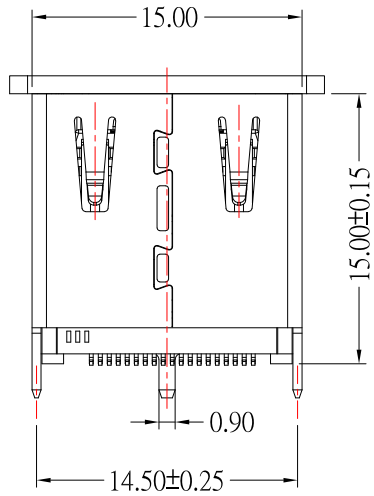

CONTACT 建倚科技股份有限公司
CONTACT TECHNOLOGY CORP.

TOLERANCE UNLESS OTHERWISE STATED :

Up to 5 ±0.2
Above 5 ~ 15 ±0.3
Above 15 ~ 30 ±0.4
Above 30 ~ 50 ±0.5
Angle ±0.3

3RD. ANGEL'S



UNITS

MM

DRAWN BY: Jack Lu
CHECKED BY: Jacky Chen
APPROVED BY: Tony Kao

DATE: 01/09/26
DATE: 01/09/26
DATE: 01/09/26

MATL
FINISH
SCALE
SHEET NO.

TITLE
MODLE
DWG NO.
PART NO.

CONNECTOR
HDMI AF 直立式SMT H15.0mm
HDMI-19P-VS5-S297
HDMI-19P-VS5-S297

SIZE: A4
VER: R1

1	更新圖面	Jack	010926
ITEM NO.	DESCRIPTION	DRAWN	DATE