

IP67



SBC-WP240M1-31x-S338

鍍層厚度:

Blank : 1u"
2 : 15u"
3 : 30u"

SPECIFICATIONS

Electrical:

- Rating: 5.0A(VBUS&GND),0.25A(Other Pin)
- Contact Resistance: 40 mΩ Max
- Insulation Resistance: 100 MΩ Min
- Dielectric Withstanding Voltage: 100V AC

Mechanical:

- Connector Mate and Unmate Force
 - Mate force: 5~20 N
 - Unmate force: 8~20 N

Material:

- Housing: LCP,UL 94V-0
- Contact: Copper Alloy
- Shell: SUS
- Glue Water: Epoxy

Finish:

- Contact: Plated Gold in Mating Area ;
Gold Plated on Solder Balls ;
Nickel under plated overall
- Shell: Nickel under Plated surface layer

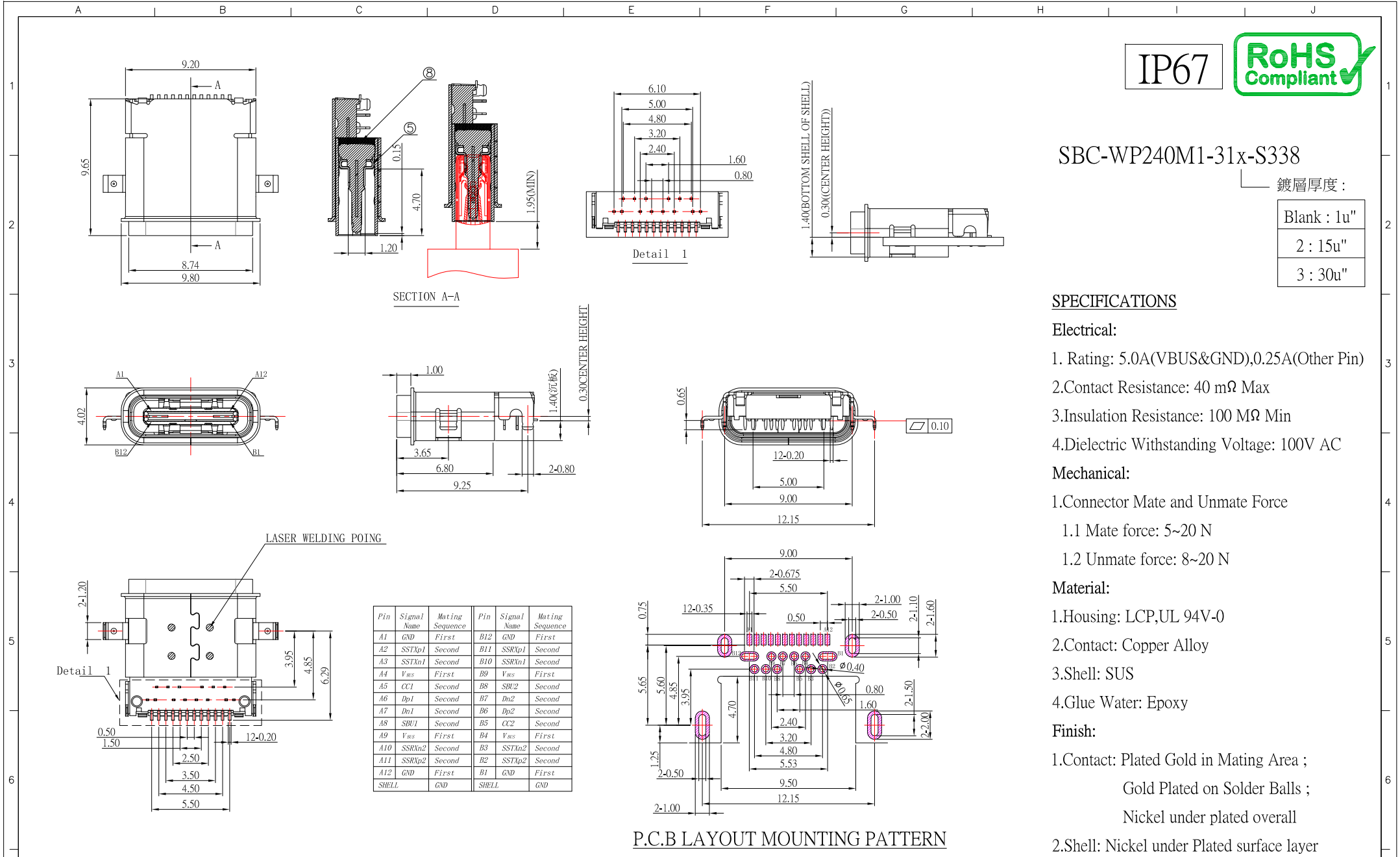

4	新增防水膠料號	Jack	060321
3	更新防水等級	Jack	062519
2	更新為A0版	Jack	110117
1	更新防水等級	Jack	090717
ITEM NO.	DESCRIPTION	DRAWN	DATE

CONTACT 建倚科技股份有限公司
CONTACT TECHNOLOGY CORP.

TOLERANCE UNLESS OTHERWISE STATED:
 Up to 5 ±0.2
 Above 5 ~ 15 ±0.3
 Above 15 ~ 30 ±0.4
 Above 30 ~ 50 ±0.5
 Angle ±0.3°

3RD. ANGEL'S

UNITS MM

DRAWN BY:	DATE	MAT'L	TITLE	CONNECTOR
Jack Lu	06/03/21			
CHECKED BY:	DATE	FINISH	MODLE	USB 3.1 TYPE C 沉板式防水型 IP67
Jacky Chen	06/03/21			
APPROVED BY:	DATE	SCALE	DWG NO.	SBC-WP240M1-31x-S338
Tony Kao	06/03/21	1 : 1	PART NO.	SBC-WP240M1-31x-S338
		SHEET NO.	1 of 2	SIZE A4
				VER R4

建議密封方式

IP67

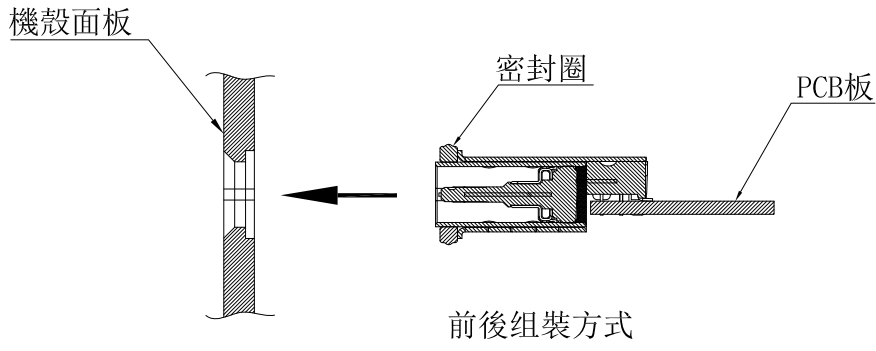

前後組裝方式

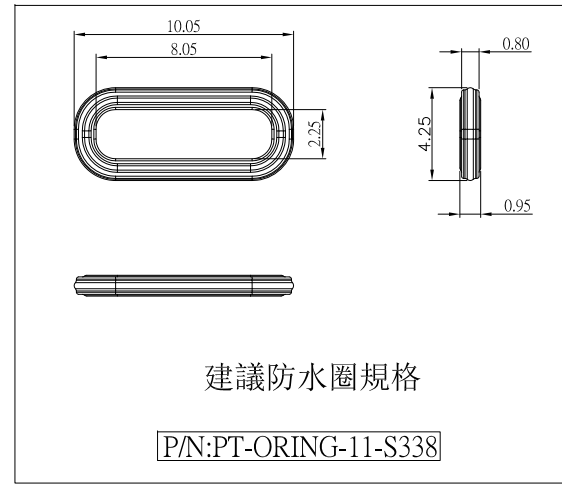

機殼面板對密封圈與縮量0.30Min
(建議壓縮量為密封圈直徑大小40~50%)

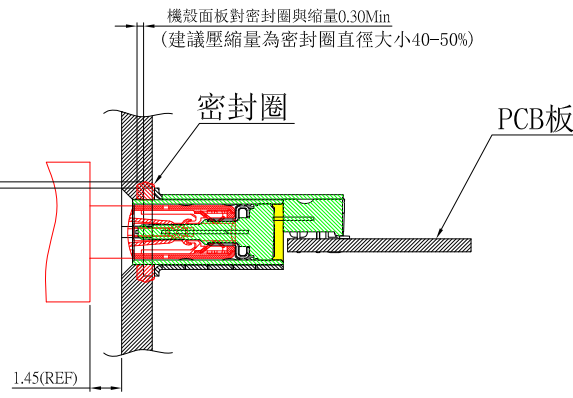

組裝面板後公母頭對插示意圖

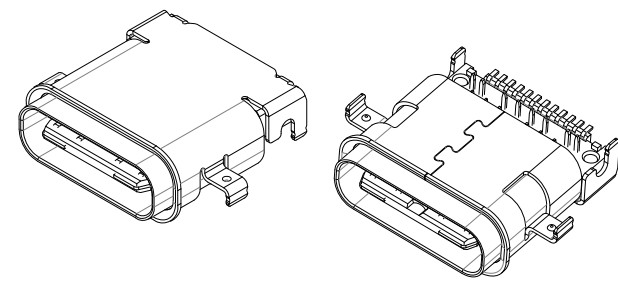

4	新增防水膠圈料號	Jack	060321
3	更新防水等級	Jack	062519
2	更新為A0版	Jack	110117
1	更新防水等級	Jack	090717
ITEM NO.	DESCRIPTION	DRAWN	DATE

CONTACT 建倚科技股份有限公司
CONTACT TECHNOLOGY CORP.

TOLERANCE UNLESS OTHERWISE STATED:
 Up to 5 ±0.2
 Above 5 ~ 15 ±0.3
 Above 15 ~ 30 ±0.4
 Above 30 ~ 50 ±0.5
 Angle ±0.3°

3RD. ANGEL'S

UNITS MM

DRAWN BY:	DATE	MAT'L	TITLE	CONNECTOR
Jack Lu	06/03/21		MODLE	USB 3.1 TYPE C 沉板式防水型 IP67
CHECKED BY:	DATE	FINISH	DWG NO.	SBC-WP240M1-31x-S338
Jacky Chen	06/03/21		SCALE	1 : 1
APPROVED BY:	DATE	SHEET NO.	PART NO.	SBC-WP240M1-31x-S338
Tony Kao	06/03/21	2 of 2		