

CIRCUIT DIAGRAM

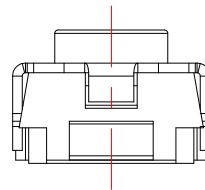

MODEL NO.	TS-A85U	TS-A85AU
L (mm)	2.0	2.5

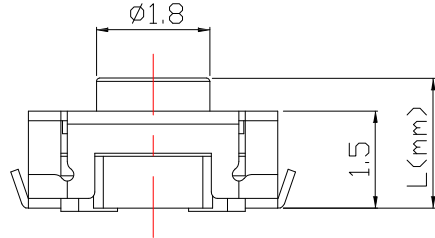
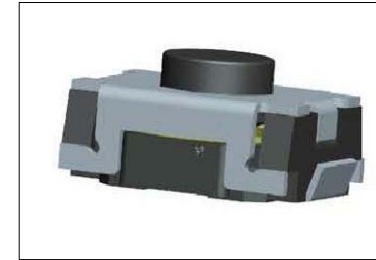
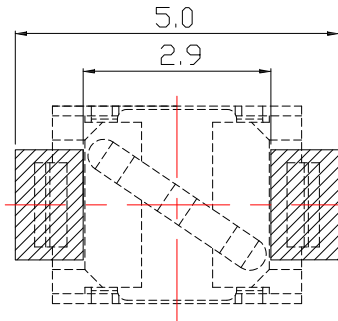
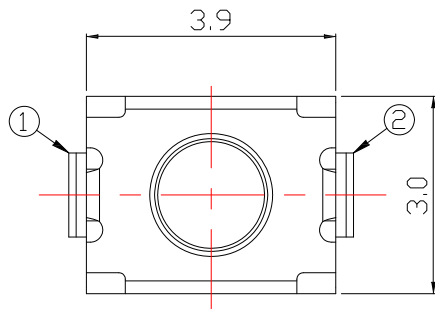

P.C.B. LAYOUT MOUNTING PATTERN

SPECIFICATIONS

Rating	DC 12V 50mA		
Contact Resistance	100mΩ Max.		
Travel	0.15 ± 0.1mm		
Operating Force	2 160±30gf	3 250±50gf	
Operating Life(cycles)	100,000		

2	更新travel	Jack	070815
1	删除1.80高度选项	Jack	110714
ITEM NO.	DESCRIPTION	DRAWN	DATE

CONTACT 建倚科技股份有限公司
CONTACT TECHNOLOGY CORP.

TOLERANCE UNLESS OTHERWISE STATED:

Up to 5 ±0.2
Above 5 ~ 15 ±0.3
Above 15 ~ 30 ±0.4
Above 30 ~ 50 ±0.5
Angle ±0.3°

3RD. ANGEL'S



UNITS MM

DRAWN BY:	DATE	MAT'L	TITLE	SWITCH
Jack Lu	07/08/15		MODLE	TACT SWITCH
CHECKED BY:	DATE	FINISH	DWG NO.	TS-A85xU-x-S126
Jacky Chen	07/08/15		PART NO.	TS-A85xU-x-S126
APPROVED BY:	DATE	SCALE	SHEET NO.	1 of 1
Tony Kao	07/08/15	1 : 1		

SIZE A4
VER R2