

P.C.B LAYOUT
TOP VIEW

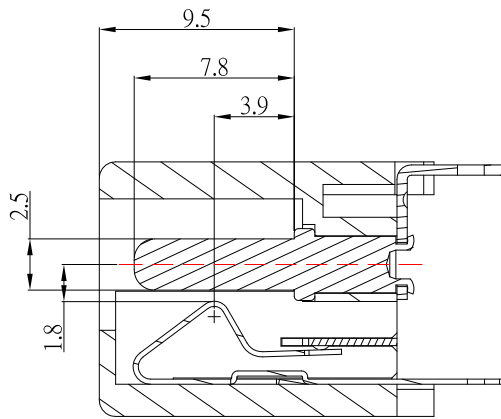

SECTION A-A

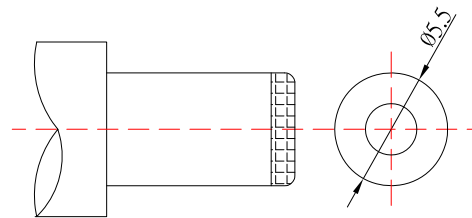
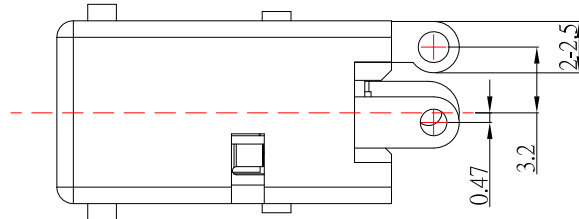

DC MATE PLUG

MODEL NO.	DC-077-x-A-TN
SCHEMATIC	
CENTER PIN(X)	$\phi 2.0$ mm $\phi 2.5$ mm

SPECIFICATION

1. Rating : DC 16V 5.0A
2. Contact resistance : $\leq 30m\Omega$
3. Insulation resistance : $\geq 100M\Omega$
4. Withstand voltage : 500VAC
5. Insertion and extraction force : 3-20N
6. life test : 5,000 cycles

ITEM	PART NAME	MATERIAL	QTY	REMARK
5	HOUSING	PA66	1	BLACK
4	CENTER PIN	BRASS	1	TIN-PLATING
3	TERMINAL 3	BRASS	1	TIN-PLATING
2	TERMINAL 2	BRASS	1	TIN-PLATING
1	TERMINAL 1	PHOSPHOR BRONZE	1	NI-PLATING

CONTACT 建倚科技股份有限公司
CONTACT TECHNOLOGY CORP.

TOLERANCE UNLESS OTHERWISE STATED :
 Up to 5 ± 0.2
 Above 5 ~ 15 ± 0.3
 Above 15 ~ 30 ± 0.4
 Above 30 ~ 50 ± 0.5
 Angle ± 0.3

3RD. ANGEL'S

 UNITS MM

DRAWN BY:	DATE	MAT'L	TITLE	JACK
Jack Lu	08/30/18	FINISH	MODLE	DC JACK
CHECKED BY:	DATE	SCALE	DWG NO.	DC-077-x-A-TN-S214
Jacky Chen	08/30/18	SHEET NO.	PART NO.	DC-077-x-A-TN-S214
APPROVED BY:	DATE			
Tony Kao	08/30/18			

ITEM NO.	DESCRIPTION	DRAWN	DATE
1	更新SCHEMATIC	Jack	083018