

HDMI-19P-D08x-S273

鍍層厚度 :

Blank : 1u"
2 : 15u"
3 : 30u"

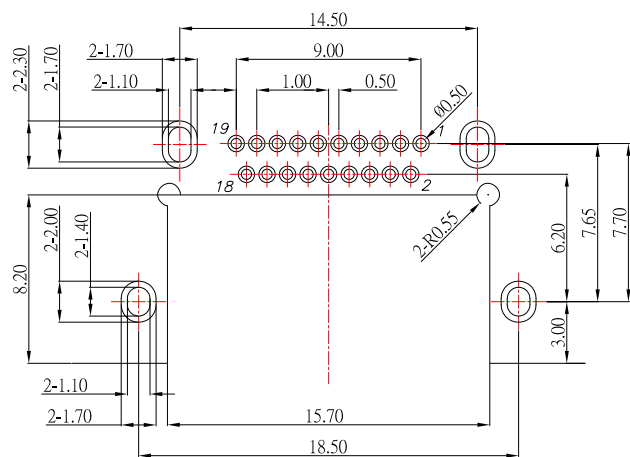

RECOMMENDED PCB LAYOUT(TOP VIEW)

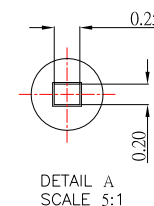
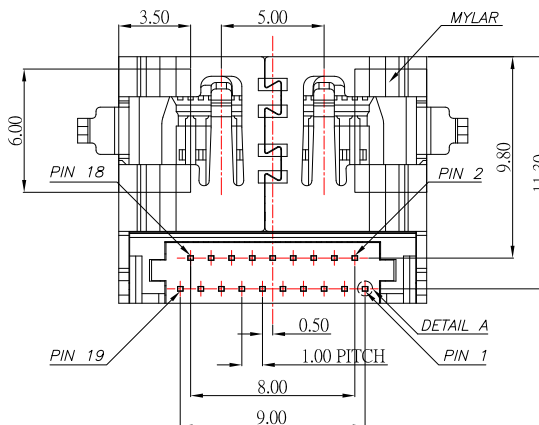

Material:

- 1.Housing: High Temperature Thermoplastic,UL 94V-0
2. Cover: High Temperature Thermoplastic,UL 94V-0
- 3.Contact: Phosphor Bronze
- 4.Shell: Stainless Steel

Finish:

- 1.Contact: Plated Gold in Mating Area ;
Gold Plated on Solder Balls ;
Nickel under plated overall
- 2.Shell: Nickel under Plated surface layer

CONTACT 建倚科技股份有限公司
CONTACT TECHNOLOGY CORP.

TOLERANCE UNLESS OTHERWISE STATED :

Up to 5 ±0.2
Above 5 ~ 15 ±0.3
Above 15 ~ 30 ±0.4
Above 30 ~ 50 ±0.5
Angle ±0.3°

3RD. ANGEL'S



UNITS MM

DRAWN BY:	DATE	MAT'L	TITLE	CONNECTOR
Jack Lu	06/10/15	FINISH	MODLE	HDMI A/F 沉板式 DIP 板上 H:2.43mm
CHECKED BY:	DATE	SCALE	DWG NO.	HDMI-19P-D08x-S273
Jacky Chen	06/10/15	1 : 1	PART NO.	HDMI-19P-D08x-S273
APPROVED BY:	DATE	SHEET NO.		
Tony Kao	06/10/15	1 of 1		

ITEM NO.	DESCRIPTION	DRAWN	DATE