



# SUA-110H29x-x-S235

SHELL :

Blank : BRASS
I : SPCC

COLOR :

Black: B
White : W

## SPECIFICATIONS

### Electrical:

- 1.Contact Resistance: 30 mΩ Max
- 2.Dielectric Withstanding Voltage: 500 V AC
- 3.Insulation Resistance: 1,000 MΩ Min

### Mechanical:

- 1.Connector Mate and Unmate Force
  - 1.1 Mate force: 3.57 Kgf (Max)
  - 1.2 Unmate force: 1.02Kgf (Min)

### Material:

- 1.Housing: PBT,UL 94V-0
- 2.Contact: Brass
- 3.Shell: Brass / SPCC

### Finish:

- 1.Contact: Plated Gold in Mating Area ;  
Tin Plated on Solder Balls ;  
Nickel under plated overall
- 2.Shell: Nickel under Plated surface layer

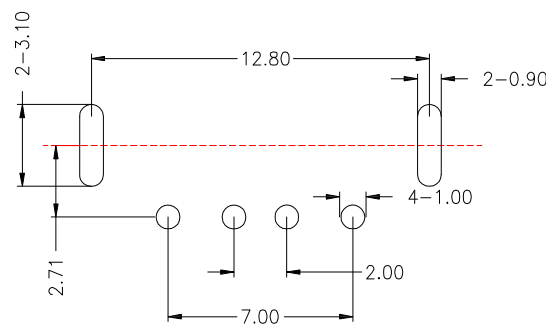
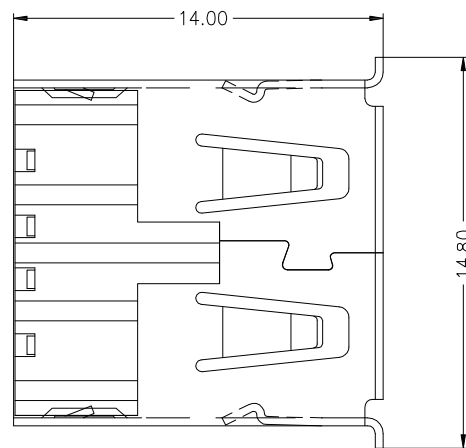
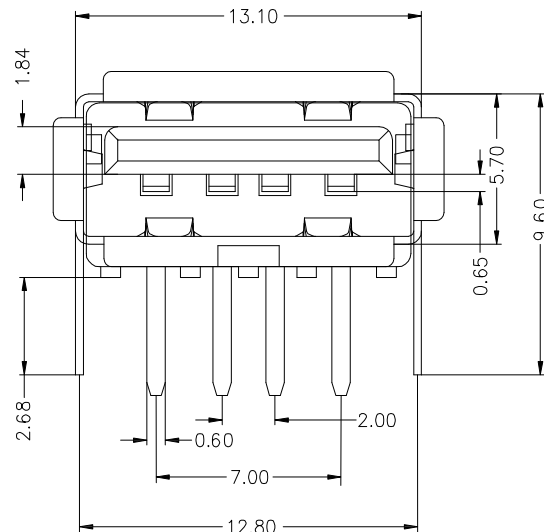
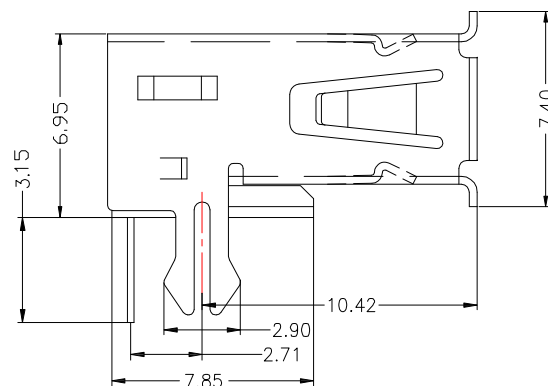

P.C.B LAYOUT MOUNTING PATTERN

2	更新尺寸	Jack	092518
1	更新尺寸及更新為A0版	Jack	061416
ITEM NO.	DESCRIPTION	DRAWN	DATE

**CONTACT** 建倚科技股份有限公司  
CONTACT TECHNOLOGY CORP.

TOLERANCE UNLESS OTHERWISE STATED:

Up to 5 ±0.2  
Above 5 ~ 15 ±0.3  
Above 15 ~ 30 ±0.4  
Above 30 ~ 50 ±0.5  
Angle ±0.3°

3RD. ANGEL'S



UNITS MM

DRAWN BY:	DATE
Jack Lu	09/25/18
CHECKED BY:	DATE
Jacky Chen	09/25/18
APPROVED BY:	DATE
Tony Kao	09/25/18

MAT'L		TITLE	CONNECTOR
FINISH		MODLE	USB A/F 90度 魚叉腳 無後蓋
SCALE	1 : 1	DWG NO.	SUA-110H29x-x-S235
SHEET NO.	1 of 1	PART NO.	SUA-110H29x-x-S235
		SIZE	A4
		VER	R2