

P.C.B LAYOUT MOUNTING PATTERN  
(TOP VIEW)

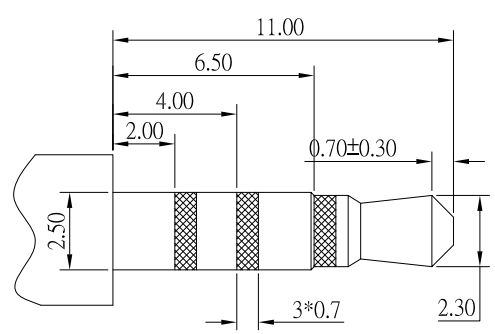

Ø2.50mm 4 POLE PLUG

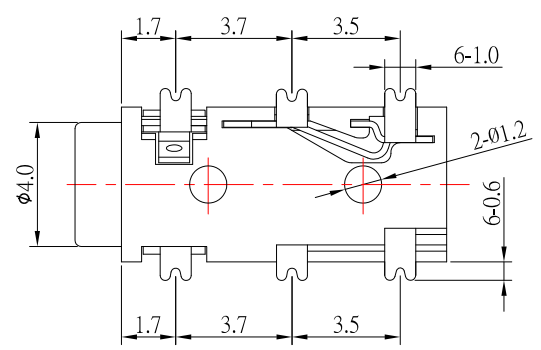

MODEL NO.	PI-2866D-H3	PI-2864D-H3
SCHEMATIC		

- SPECIFICATION**
- Rating: DC 30V, 1.0A
  - Contact resistance:  $\leq 50m\Omega$
  - Insulation resistance:  $\geq 100M\Omega$
  - Withstand voltage: 500VAC
  - Insertion and extraction force: 3-20N
  - life test: 5,000 cycles

NO.	DESCRIPTION	QTY	MATERIAL	REMARK
⑦	HOUSING	1	PA9T	
⑥	CONTACT FOOT #6	1	Phosphor Bronze	Au-Plated
⑤	CONTACT FOOT #5	1	Phosphor Bronze	Au-Plated
④	CONTACT FOOT #4	1	Phosphor Bronze	Au-Plated
③	CONTACT FOOT #3	1	Phosphor Bronze	Au-Plated
②	CONTACT FOOT #2	1	Phosphor Bronze	Au-Plated
①	CONTACT FOOT #1	1	Phosphor Bronze	Au-Plated

**CONTACT** 建倚科技股份有限公司  
CONTACT TECHNOLOGY CORP.

TOLERANCE UNLESS OTHERWISE STATED:  
 Up to 5 ±0.2  
 Above 5 ~ 15 ±0.3  
 Above 15 ~ 30 ±0.4  
 Above 30 ~ 50 ±0.5  
 Angle ±0.3°

3RD. ANGEL'S

UNITS MM

DRAWN BY:	DATE	MAT'L	TITLE	JACK
Jack Lu	01/13/17		MODLE	PHONE JACK
CHECKED BY:	DATE	FINISH	SCALE	1 : 1
Jacky Chen	01/13/17		DWG NO.	PJ-286xD-H3-S124
APPROVED BY:	DATE	SHEET NO.	PART NO.	PJ-286xD-H3-S124
Tony Kao	01/13/17	1 of 1		

ITEM NO.	DESCRIPTION	DRAWN	DATE